



MSTA **CANADA**

40th ANNIVERSARY

**2021 COMPENDIUM OF
CANADIAN MINING SUPPLIERS**

MSTACANADA™
MINING SUPPLIERS TRADE ASSOCIATION

YOUR PARTS ARE IN STOCK AT L&M

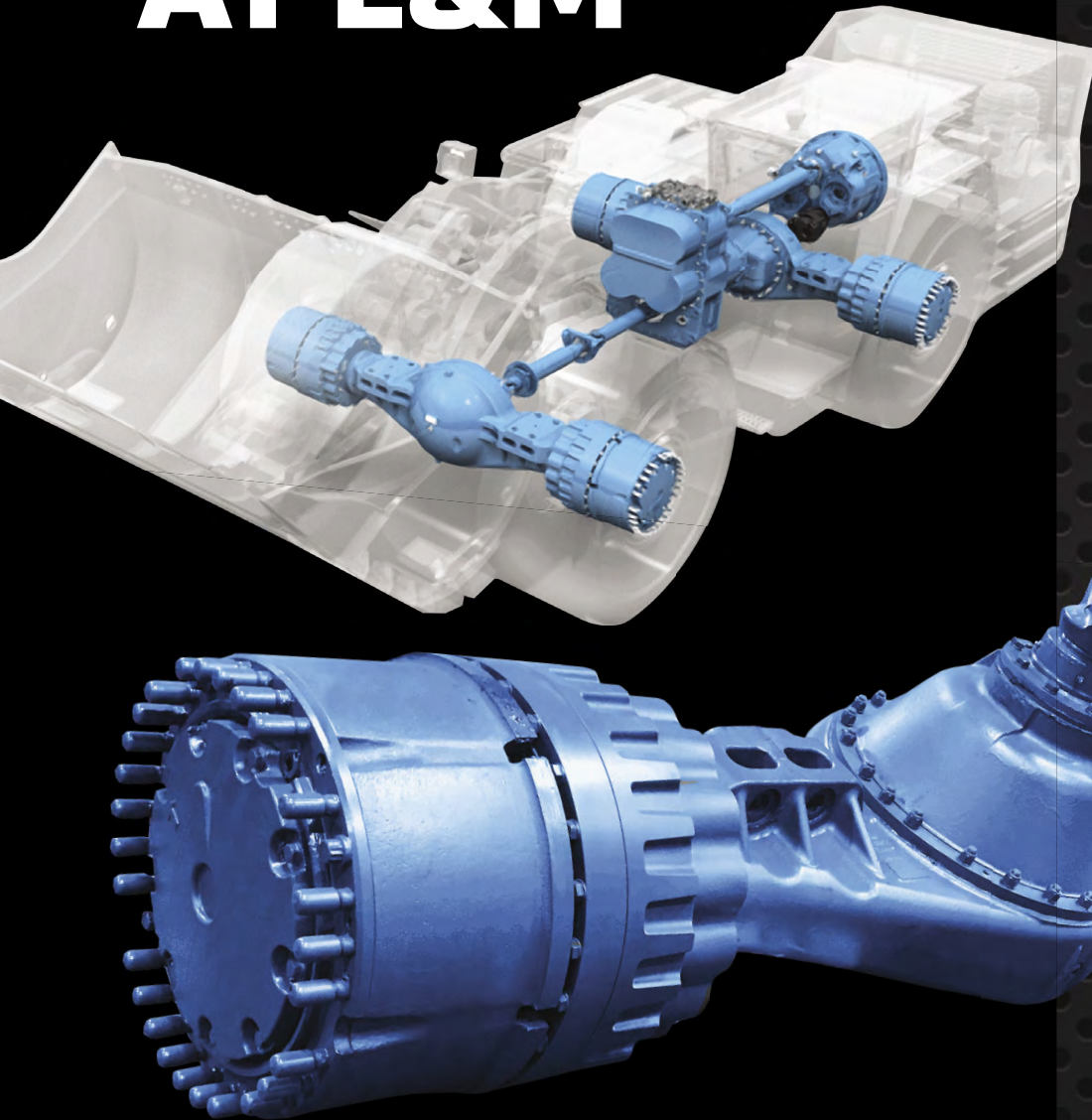

We're celebrating our 60th Anniversary thanks to the confidence our customers have shown around the world in over 100 countries. Supplying Transmission, Torque Converter, Differential, and Planetary Axle parts from all the top OEM's. L&M Powertrain; the worlds heavy equipment parts & component supplier that always has your part in stock!



Celebrating 60 Years
of Service Worldwide

L&M POWERTRAIN PARTS LIMITED
201 Snidercroft Road, Concord, Ontario, Canada L4K 2J9
Telephone: 905-669-2292 Fax: 905-669-6319
Toll-Free in North America: 1-800-387-3765
Email: parts@landmparts.com

LMPOWERTRAINPARTS.COM

PLEASE SEE OUR LISTING ON PAGE 66

Visit Us at Booth #1750 North Hall



2021
MINEXPO
INTERNATIONAL
SEPTEMBER 13-15, 2021
LAS VEGAS, NEVADA, USA



SPICER
Off-Highway Systems

KESSLER

EATON

CLARK-HURTH
COMPONENTS

TIMKEN

AXLETECH



MERITOR

Managing Director
Ryan McEachern
mceachern@mstacanada.ca

Director – Global Events
Dolores Wharton
wharton@mstacanada.ca

Manager – Business Development
Stephanie Alvarez
alvarez@mstacanada.ca

Office Manager
Linda Collins
collins@mstacanada.ca

Digital Marketing Consultant
Daniel Matthews, Matthews Marketing
dan@matthewsmarketing.ca

Editorial Services
Cheryl Carter, Wordslinger Inc.
cheryl@wordslinger.ca

Art Direction and Design
Jill Hansen, Hansen Design
connect@hansendesign.ca

**Mining Suppliers Trade Association Canada
(MSTA CANADA)**

Suite 130, 7111 Syntex Drive
Mississauga, Ontario L5N 8C3
Canada
Phone: 1-647-929-MSTA (6782)
Email: minesupply@mstacanada.ca
www.mstacanada.ca



All rights reserved. Reproduction of any portion of this publication without written permission from MSTACANADA Inc. is strictly forbidden.



25TH EDITION

CONTENTS

- 3 WELCOME MESSAGE**
- 5 THE HISTORY OF MSTACANADA**
- 10 SUBSECTOR INDEX OF MEMBER COMPANIES**
- 16 THE DIG**
- 17 CORPORATE PROFILES OF CANADIAN MINING SUPPLIERS BY SUBSECTOR**
- 74 MEMBER STORIES**
- 90 MSTA STAFF AND BOARD OF DIRECTORS**
- 91 INDEX OF MSTACANADA MEMBERS**



WELCOME

Welcome to our very special edition of MSTA CANADA's annual Compendium of Canadian Mining Suppliers!



A message
from your Managing Director
Ryan McEachern

A handwritten signature in black ink, appearing to read 'Ryan McEachern'.

As Managing Director for the Mining Suppliers Trade Association Canada (MSTA CANADA), I am very proud to present this special edition of our Compendium. With this publication, we are celebrating two major milestones for our association. Firstly, the association marks its 40th anniversary serving the mining supply and services (MSS) sector. Secondly, we celebrate the 25th edition of the Compendium of Canadian Mining Suppliers, an industry-recognized publication showcasing great Canadian companies providing world-class products and services to the mining industry around the world.

In this special issue, we take a walk down memory lane, starting with the great story of how we got off the ground and evolved and grew into a national organization that is now known as the Mining Suppliers Trade Association Canada or MSTA CANADA. We also hear the stories from our dedicated members who were there at the beginning and who continue to support and benefit the association.

I want to thank The Honourable Mary Ng, Minister of Small Business, Export Promotion and International Trade for her letter recognizing this important occasion. Finally, I want to give my heartfelt thanks to all of you – the members we have had the great pleasure of working with; the boards of directors who have served us over the years; the passionately dedicated staff, both past and present; and the partners we have worked with over the years and decades. It is only with your support that we have achieved this incredible milestone.

Sincerely,
Ryan McEachern

mstacanada.ca





Ottawa, Canada K1A 0G2

March 12, 2021

Mr. Ben Sharpe
Chairperson
Mining Suppliers Trade Association Canada
7111 Syntex Drive, suite 130
Mississauga ON L5N 8C3

Dear Mr. Sharpe:

I'm pleased to congratulate the Mining Suppliers Trade Association Canada (MSTA CANADA) on 40 years of dedicated service to the mining supply and services sector of Canada!

Our government is committed to the success of Canadian small and medium-sized enterprises, and I commend the efforts of your association to promote the growth of businesses in the mining supply and services sector. By connecting mining supply and services companies to business opportunities across Canada, and internationally, as well as providing professional development, industry news, and by supporting its members, MSTA CANADA contributes to the promotion and the advancement of a responsible, sustainable, and inclusive industry.

MSTA CANADA is a valued partner of our government and of Canada's Trade Commissioner Service (TCS) around the world. Together we share a common goal—supporting Canadian businesses in their international business endeavours. Whether it is introducing Canadian businesses directly to potential customers or connecting companies to local businesses for strategic partnerships and supports for their respective products or services, our government, the TCS, and MSTA CANADA have worked side by side to make those connections.

Again, congratulations MSTA CANADA on celebrating 40 years as Canada's national voice for the mining supply and services sector. We look forward to continuing our successful partnership with you.

Sincerely,

A handwritten signature in black ink that reads "Mary Ng".

The Honourable Mary Ng, P.C., M.P.

40 YEARS STRONG: FROM AN IDEA TO A NATIONAL TRADE ASSOCIATION



From a handful of individuals, to hundreds of united businesses with a national voice - we've travelled a long way in 40 years!

The idea of what is now MSTA CANADA began 40 years ago, on the deck of a hotel swimming pool in Lima, Peru. On that sunny afternoon, as a group of trade mission delegates relaxed after a long day, an idea crystalized, one that involved many individual companies banding together to create a strong, unified voice for the Mining Supply and Services sector.

That originating theme of “strength in numbers” has been a constant thread woven throughout the tapestry of the association's history.

With support from Peter Kloplic, Ontario Government, who led



the trade mission in Peru, the group officially established Ontario Mining Equipment and Services for Export (OMESE). John Needham was chosen by the first Board of Directors to head up the fledgling organization as the first Managing Director. John hired Linda Collins as the office manager; a position she still holds today, and the team of two got to work.

John Needham's mandate was to sign up new members and grow the association. Eventually OMESE became large enough to create a binder containing a

directory of members to promote their respective products and services. A pamphlet version of the directory, small enough to fit in a suit pocket, was also developed to distribute at events.

Under John's leadership, the organization quickly became a national association, with a subsequent name change in 1989 to the Canadian Association of Mining Equipment and Services for Export (CAMESE). Broadening the scope to the national level was an important strategic move to capture interest from the federal government.





An important turning point

Sadly, John's health declined, and he passed in 1992, leaving the association at a crossroads – to fold or to find someone to lead the organization. Fortunately, a small group of champions recognized the value of uniting under the CAMESE banner and eventually convinced the remaining members to vote in favour of keeping the organization moving forward. Ross Lawrence, President at that time, joined together with John Hepburn (John T. Hepburn Limited) and Frank Aimone (Heath & Sherwood (1964) Limited) to become a search committee for a new managing director. At that time, Jon Baird was available and, with his extensive experience in sales and marketing to the industry, international travel experience and ability to speak multiple languages, was the most qualified to lead the organization. He was hired as Managing Director in 1993 and with Jon at the helm, CAMESE experienced a rebirth.



One of Jon's first initiatives was a campaign in the spring of 1993 to grow the membership. "My target was to get it up to 100 members within the year. That meant we needed to attract 72 new members, which was quite ambitious," says Jon. Jon's belief in the viability and necessity of the organization was so strong that he took half the salary and loaned the money to the organization.

Jon's work in those early days was carried out in a small office in Toronto's North York area with Linda Collins as his office manager. "Linda was always our anchor," says Jon. "Not only does she know everything about the organization, but she also cares deeply about its successes and its members."

Once Jon's aggressive membership goals were achieved, he turned his attention to providing more value-added services.



International exposure

One of the first member services to be added was the development of a trade show program, along with missions connected to those trade shows, with the goal of leveraging the Canada brand. The association organized Canada Pavilions, which were populated by mining supply firms at upwards of 12 mining trade shows a year. Instead of being scattered here and there on the trade show floor, companies could now unite under the pavilion, which increased member visibility and better promoted them at these events. Through exposure at trade shows in 23 countries, the Canada Pavillion quickly became a gathering point that drew the interest of international mining companies attracted to the globally recognized "Made in Canada" brand.

Expanding resources

With all of the added member services, it quickly became apparent that additional resources were needed. Jon put together a plan to add staff and further enhance the benefits to members. A key success factor was the multi-year government support that helped fund additional staff members and a move to a larger office in Markham, just north of the City of Toronto, in 1996.

"Having our own office space and additional personnel provided the strength for the organization to really flourish," notes Jon.



Advocating for members

While increasing exposure to business opportunities for members continues to be mission critical for the association, advocating on behalf of members has also been a cornerstone of our mandate from the earliest days.

“Individually, we were too small to get attention, but collectively, we mattered,” says Leo Fox (Phoenix Geophysics), a charter member. “Having a unified voice to speak to the government was essential because we’re not top of mind for them. Our presence forced them to take our sector into account.”

A key issue has always been that there was no sectoral coordination with mining supply and services companies. While the mining industry is named and recognized, there is no accounting of, or special support for, the companies that supply the mining industry – it is a hidden sector. Statistics Canada, for example, had never compiled statistics on the Mining Supply and Services sector.

“The organization recognized early on that we needed a continuing program to inform the government about what is required to be competitive in the world,” says Jon, “so we worked with the Mining Association of Canada and the Prospectors and Developers Association of Canada, associations that represent the mining companies, to advocate for all of the mining industry, not just suppliers.”



A vision for the future

In 2014, Jon officially retired, leaving a powerful legacy for the association and a membership of over 300 companies. It was in the fall of that year that the board of directors brought on Ryan McEachern to take over as Managing Director.



Leveraging this strong legacy, Ryan went to work, with a board mandate to modernize the association to greet the challenges of the 21st century. In 2015, the office was relocated to its current location in Mississauga, Ontario. In 2016, prior to updating the website platform, a brand equity audit was conducted and on September 14, 2017, the association was once again transformed: from CAMESE to the Mining Suppliers Trade Association Canada or MSTA CANADA.

We listened to our stakeholders, and the new brand better reflects the activities the members want from the association,” explains Ryan. “Mining suppliers’ is a much more inclusive term for our existing and future members, and although export will always be a very important part of our programming, ‘trade’ is a more comprehensive description of what we focus on. The rebranding also comes with a very clear mandate – to connect members to opportunities to grow their respective businesses.”

Key among Ryan’s goals: finding the best way to embrace the technology that will propel the organization into a new era. That includes more contemporary visual branding that injects more energy into all of MSTA CANADA’s communications, a revitalized website and, most recently, a new weekly videocast series called MSTA CANADA’s “The DIG,” an interview format show that explores timely stories relevant to the MSS sector.





Writing the next chapter

From independent companies working in isolation... to what Leo Fox described as a “good and scrappy little trade organization” with a small footprint and big ambitions... to a national organization with a voice in Ottawa, MSTA CANADA has indeed come a long way in 40 years.

“There’s no doubt we’ll face new challenges even as we all work through the pandemic and whatever it leaves in its wake,” says Ryan. “But my experience has seen that there are always exciting opportunities that can be discovered and when I look at the major trends, this is going to be an extremely exciting decade of new opportunities. And we can better capture them as a united force just like that small group of gentlemen sitting around a hotel pool in Peru envisioned 40 years ago.”



25 YEARS OF THE COMPENDIUM

Two and a half decades ago, the original member catalogue, in loose-leaf binder format, was transformed into an annual magazine called the Compendium of Canadian Mining Suppliers. The contents included an alphabetical listing of all members, paid member profiles and industry-related articles.

Thousands of copies of the Compendium were distributed widely: to members, mining companies, international trade show delegates and Canadian embassies; to on-demand requests through various direct response mechanisms; and by the boxful to government agencies including the Department of Foreign Affairs and International Trade.

Says charter member Leo Fox (Phoenix Geophysics), “the Compendium has always been a huge benefit to members because it makes them visible to a wide range of people around the globe. You never know who might be interested in your company – but the Compendium gets your name out there so you can be found.”

In 2019, the Compendium got a fresh new look to better reflect MSTA CANADA’s new branding. Following the business disruptions of the pandemic, the 2021 edition is being distributed exclusively in electronic format for the first time ever – an adaptation that will enable us to reach an even wider audience.

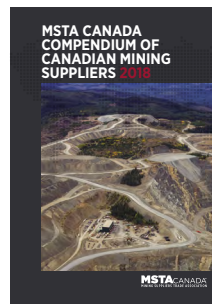

SUBSECTOR INDEX OF MEMBER COMPANIES

This index is a compilation of profiles briefly describing the activities and capabilities of all members appearing in this year's MSTA CANADA Compendium of Canadian Mining Suppliers. For ease of reference, members' profiles are organized under the mining industry subsectors they supply or serve.

ANALYTICAL LABORATORIES & SUPPLIES

Geochemical, ore, process and environmental sample analysis; umpire assay services; laboratory equipment; density measurements; conductivity measurements; susceptibility; IP/resistivity.

17 Laval Lab Inc.

Leading supplier of laboratory and pilot plant equipment

ASSET MANAGEMENT

Mobile and fixed asset management, risk assessments and audits, inspection and condition-based reliability programs, asset tracking, logistic support analysis; life cycle costing; maintenance strategy; outsourcing; cost-benefit analysis; disposal; and renewal.

18 Global Physical Asset Management, Inc.

Innovative Risk Solutions - Driven by Data™

ASSOCIATIONS

Activities of national, provincial and regional trade associations for the Canadian mining industry.

20 Greater Sudbury Economic Development

Canada's Resourceful City

22 Prospectors & Developers Association of Canada (PDAC)

The voice of Canada's mineral exploration and development industry

AUTOMATION & COMMUNICATIONS

Expertise, equipment and technology for process and machinery automation; business intelligence tools; robotics; underground and surface communications; vehicle automation, monitoring and safety.

24 Hepburn Engineering Inc.

Complete hoisting systems, electrical controls, software and automation

BLASTING EQUIPMENT, PRODUCTS & SERVICES

Explosives, manufacturing systems, explosive delivery systems, blast-monitoring analysis equipment and consulting

25 Attwell Plastics Corporation

Manufacturing plastics since 1980



BULK MATERIAL HANDLING EQUIPMENT, SYSTEMS & ENGINEERING SERVICES

Components, equipment, engineering design and consulting services for moving bulk materials, including fabricators of skips, cages, loaders, unloaders, mine-cars, rock breakers, samplers, conveyor systems, rollers, idlers, pulleys, vulcanizers, mixers, filters, speed reducers, motors, stackers, reclaimers, grizzlies, chutes, chute loading systems, slusher hoists, tramp metal detectors, belt rip detection systems, drive control systems, abrasion-resistant piping, castings and gears.

26 **Almex Group**

Leader in conveyor belt vulcanizing and repair equipment

27 **Rail-Veyor Technologies Global Inc.**

Moving material hauling in a whole new direction

CAMERA SYSTEMS, MOBILE

Thermal night vision cameras, no-drill laptop mounts, remote-control floodlights, side-view cameras, backup cameras, video accident recorders; truck video products; digital incident/accident recording systems; rear-view video systems; submersible lamps; emergency lighting, warning lights, D.O.T. lighting, reversing aids.

28 **Motion Metrics**

Advanced monitoring solutions for mines and quarries

29 **PROVIX Inc.**

PROVIX = Now I can see!

CONSULTING GEOLOGISTS & ENGINEERS

Services in geology, project development, ore reserve estimation, feasibility studies; due diligence, project monitoring, failure analysis, engineering for mining, metallurgy, mechanical, civil, electrical, geotechnical; turnkey contracting, research and development.

30 **RWDI**

You have a vision. We make it possible.

DIESEL ENGINE ACCESSORIES

Engineering design, innovation, equipment and component manufacturing for diesel powered engines.

31 **Intelline Inc.**

Dependable Power, Less Fuel

ELECTRIC POWER EQUIPMENT

Electrical components and management tools, power resistors, power cables, power cable couplers, ground fault protection systems, electric drive raise climbers, ruggedized equipment, starters, high voltage equipment, switchgear, electric generators, batteries.

33 **Adria Power Systems**

A premier manufacturer of custom-engineered electrical equipment designed for use in mining

34 **Mine Cable Services Corporation**

Cable connection systems, repair equipment and handling systems



ENVIRONMENTAL EQUIPMENT & SERVICES

Information, professional services and technologies covering environmental science, planning and engineering for mines and processing; treatment of sewage and acid mine effluents; mine closure services, engine emissions control, water treatment equipment and services, wastewater treatment, environmentally sound exploration practices; portable storage systems; liquid logistics; onsite storage tanks for water and fuel; pest control; secondary containment for hazardous fluids both military and commercial.

35 **ECO Technologies**

Dredging for mine tailings and industrial lagoons

37 **Titan Environmental Containment**

Specializing in high quality geosynthetics, containment systems, and specialty civil engineering

EQUIPMENT AND COMPONENTS

General equipment and components for the mining industry.

38 **Aspen Custom Trailers**

Choose Aspen - HAUL MORE

EQUIPMENT MAINTENANCE & REPAIR

Solutions to unique maintenance and repair problems, filtration, rebuilds, portable align boring machines, abrasion-resistant steel, blades, wear studs, plastic components, abrasion and corrosion-resistant coatings, rewinds and repairs to motors, repairs and replacements for bushings, wear plate impact pads and lining materials, jacks, welding supplies, ground engaging tools, tires.

39 **Eutectic Canada Inc.**

Cost-effective repair and maintenance solutions

40 **Valley Blades Limited**

Replacement wearing edges for earth and snow removal equipment

GEOPHYSICAL INSTRUMENTATION

Airborne, surface and borehole instrumentation for mineral exploration and other applications, including electromagnetics, magnetics, magnetotellurics, induced polarization, seismic surveying.

41 **GEM Systems Inc.**

Overhauser, potassium and proton precession magnetometer technologies

42 **Terraplus**

Your source for geophysical instruments



HEALTH & SAFETY

Health and safety supplies, footwear, cap lamps, communications and charging systems, protection systems integration, warning systems, worker protection systems and components; health risk management and environmental disease detection.

43 Horne Conveyance Safety Ltd.

Advanced engineered safety solutions and systems

44 TopVu

Experts in the application of technology in mining

HOISTING EQUIPMENT & SERVICES

Services for the design, supply, upgrading and refurbishment of mine hoists, rack-and-pinion hoists, winches, tuggers, sheaves, slushers, wire rope and wire rope testing equipment.

45 Hepburn Engineering Inc.

Complete hoisting systems, electrical controls, software and automation

MINERAL PROCESSING EQUIPMENT & SUPPLIES

Crushers and parts, grinders, ore-processing plants, electrical motors, grinding rods, mill liners, process heating equipment, centrifugal concentrators, wet and dry process filtration, electrolytic cells, process control samplers, retorts, grizzlies, screens, pumps, pump parts, castings and assemblies, clarifiers, samplers, mixers, dryers, filters, agglomerators, cyclones, gears, ceramic corrosion-resistant lining systems, rubber products such as abrasion-resistant liners, corrosion control coatings, pinch valves, hoses and expansion joints, rubber components, fibreglass reinforced parts such as pipe, grating and solvent extraction systems, abrasion-resistant piping, remanufactured and used equipment.

46 American Biltrite Ltd.

Premium abrasion-resistant rubber for total protection

47 Boundary Equipment Co. Ltd.

Engineered wear parts for mining, material handling, smelting

48 Canadian Wear Technologies

Wear solutions for critical and severe applications

49 Heath & Sherwood

Sampling systems, online XRF analysis, Tuyère line products

50 McCloskey International

Manufacturers of portable crushers, screeners and conveyors

MINERAL PROCESSING PUMPS, PIPES & VALVES

Abrasion-resistant pipe, high-density polyethylene pipe and fittings.

51 Green Canpump Inc.

Winning solutions for high pressure pumps

52 HydroTech Mining Inc.

The new wave in mine dewatering



MINERAL PROCESSING SERVICES

Process engineering; mineral processing, hydrometallurgical, pyrometallurgical and refining design and testing; crusher refurbishment; flowsheet development; pilot plants; new, remanufactured and custom-designed equipment for mineral processing.

53 Coding Metrology Inc.

Measurement and metrology automation

54 COREM

World-class expertise in mineral processing

MINING INSTRUMENTATION

Control and monitoring instrumentation, airflow monitoring; laser alignment, cavity monitoring, tramp metal detection, drill hole surveying, gas and environmental monitoring, geotechnical monitoring.

55 SightPower Inc.

Underground data-modelling systems and technology solutions

PACKAGING SERVICES

Services including design and manufacturing of packaging, crating export packaging, tracking, vacuum sealing cargo, packaging dangerous goods, loading containers, and project management and warehousing.

57 Element International Trade Inc.

Your Reliable Solution Partner

58 Topax Protektive Packaging

Protecting assets from transportation and storage hazards

SOFTWARE

Management, processing, analysis, display and presentation of exploration, mining, geomechanics, process and environmental data; ore reserve calculations; mine-wide information systems, process control and optimization; mine planning, GIS; training; laboratory information systems; hardware and business software, information technology systems.

59 ThreeDify Inc.

Next generation mining software solutions

SURFACE MOBILE EQUIPMENT & COMPONENTS

New and used surface mining machinery, dumpers, pins and bushings, engine cooling fans, climate control systems, haulers, hydraulic seals, pistons, pumps and bearings, wheels, rims, tires, tire handlers and manipulators, machinery parts and attachments, braking resistors, brake systems, clutch systems, cable reelers, dozer blades, buckets; gears; used and reconditioned equipment.

61 Boundary Equipment Co. Ltd.

Engineered wear parts for mining, material handling, smelting

62 Valley Blades Limited

Replacement wearing edges for earth and snow removal equipment



TRANSPORTATION & LOGISTICS

Service providers services including customs documentation, shipping, material handling, document preparation and cargo tracking, logistics software, export packaging, logistics, transportation, supply chain management, freight forwarding, third-party contract charters for air/sea, transportation management, risk management and heavy lift.

63 **Cole International Inc.**

The right solutions for your global logistics needs

UNDERGROUND VEHICLES, EQUIPMENT & COMPONENTS

New and used underground mining equipment; diesel engines, wheels, rims, tires, tire manipulators, rack-and-pinion hoists, machinery parts and attachments, including powertrain components, buckets, tanks, hydraulic seals, gears, castings, braking systems, wear products, electrical and automation systems, mobile service equipment.

65 **BPT Components & Parts Inc.**

Clark parts and components for underground mining equipment

66 **L&M Powertrain Parts**

Powertrain parts, the drive to serve you better

66 **MacLean**

Mining solutions

67 **Trojan Tire Inc.**

Reuse it and save!

VENTILATION EQUIPMENT & COMPONENTS

Ventilation fans; flexible ducting and accessories; airflow metering systems, gas sensors, venting systems.

69 **Accutron Instruments Inc.**

Mine and industrial ventilation monitoring with vent-on-demand

70 **G+ Industrial Plastics**

Mine ventilation performance

WATER TREATMENT EQUIPMENT & SERVICES

Technologies for water purification, wastewater treatment and acid mine drainage treatment.

72 **McCue Engineering Contractors**

All types of water. All types of solutions. All Systems Go!



MSTACANADA
MINING SUPPLIERS TRADE ASSOCIATION

THE DIG

with RYAN McEACHERN

Stay in the know with weekly episodes of MSTA CANADA's new webcast, "The Dig."

Keep informed about the most relevant news and stories affecting the mining supply and services (MSS) sector.

Watch host Ryan McEachern interview industry thought leaders.

Learn about how you can participate in MSTA CANADA-hosted events and programs

Don't miss out! Visit MSTA CANADA's YouTube channel and [subscribe now!](#)



Laval Lab Inc.



Laval Lab Inc. is the leading Canadian supplier of laboratory equipment. Laval Lab’s easy-to-use website displays the company’s complete line available for delivery around the world. Product lines include sample preparation (crushers, grinders, pulverizers), particle-size analysis (sieve shakers, particle-size analyzers, sieves),

zeta potential, sample division, XRF-sample preparation platinum labware, drying ovens and water testing instruments. Highly experienced staff takes pride in generating creative solutions to help clients increase efficiency and accuracy in laboratory analyses. For a wide range of high-quality products at a great price, visit Laval Lab online.

Contact:
Olivier Palun
 2567 boulevard Chomedey
 Laval, Québec H7T 2R2
 Canada
 Phone: 1-450-681-3883
 Fax: 1-450-681-9939
 Email: info@lavallab.com
 www.lavallab.com



ESG: THREE SOURCES OF RETURN

|  RETURN TO STAKEHOLDERS |  RETURN TO COUNTRY |  RETURN TO CITIZEN |
|--|---|---|
| STAKEHOLDER | | |
| Company shareholders | Local, provincial, and national governments | Community members Employees |
| MAIN DESIRES | | |
| Maximize company profit Retain license to operate | Maximize government revenue Provide infrastructure and social services | Share in the mining wealth Social growth and expansion |
| EXAMPLES OF IMPACT | | |
| Profit margin Net present value (NPV) Intellectual property rights Return on investment | Industrialization and transformation Job creation and transformation Political stability | Financial security Physical security Social networks Professional satisfaction |

Well-established tools exist for measuring financial return

Few tools exist for measuring/tracking socioeconomic return in a holistic manner

Source: Deloitte Tracking the Trends 2021



Global Physical Asset Management, Inc.

Risk Improvement Solutions, Reliability and Asset Optimization. Global-PAM's Engineer Team specializes in asset management (ISO 55000) of large-scale power transmission equipment for heavy industry such as mineral processing, cement, and pulp/paper. We are experts in the engineering, design, manufacture, installation, inspection, and maintenance of power transmissions and structural components for mills, kilns, driers, and crushers. Our girth gear inspections provide a complete onsite failure analysis as per AGMA 1010-F14 of the failure modes present, if any, their severity, and how these might impact the operational function

of the mill. **The final digital report provides a concise insight for the maintenance team and insurance industry on the level of exposure being presented by any operation relating to girth gear teeth.** We are experts in IsaMill and HIGmill Fine Grinding/ Stirred Milling Equipment. We provide complete Mechanical Mill Inspection and commissioning support throughout all stages of the equipment. We can create "manufacture ready" drawings from our 3D scanning that can be used to obtain various quotes for engineered components. These can be quickly adapted for variations of concepts. The asset owner keeps the drawings.

Contact:

Glenn Martin
 Field Service Specialist
 Vancouver, British Columbia
 Canada
 Phone: 1-250-762-5525
 Toll Free: 1-800-664-0822
 Fax: 1-604-648-8645
 Email: glenn@global-pam.com
 www.global-pam.com



PRODUCTS THAT RELY ON MINING FAST FACT:

Rapid test kits (gold) • Antimicrobial surfaces (copper, aluminium) • Ventilators (carbon) • Medicine (uranium, zinc) • Solar PV panels (copper, iron ore, titanium, silver, gallium, indium) • Batteries (nickel, cadmium, lithium, cobalt) • Circuitry (gold, copper, aluminium, steel, lithium, titanium, silver, cobalt, tin, lead, zinc) • Smartphones (silicon, boron, lead, barium, strontium, phosphorus, indium) • Electric cars (copper, lithium, aluminium, nickel, cadmium, cobalt, zinc) • Wind turbines (steelmaking coal, iron ore, copper, nickel) • Energy (uranium, oil sands, petroleum products) • Musical instruments (copper, silver, steel, nickel, brass, cobalt, copper, iron, aluminium) • Sports equipment (graphite, aluminium, titanium, calcium carbonate, sulphur)

Source: Facts & Figures 2020, The Mining Association of Canada



Global's Third Party Physical Asset Management Program



Increasing Production Revenue & Asset Availability while Reducing Costs

Our capabilities are in the third-party gear engineering, design, installation, inspection, risk assessment and maintenance of large girth gear systems.

Global's process provides a concise insight for the maintenance team and insurance industry on the level of exposure being presented by any operation relating to girth gear teeth.

We pride ourselves on being able to provide realistic and tailored risk improvement solutions to assist our customers' businesses through reducing the cost of risk associated with gear teeth failure events.

- ✓ Global's process satisfies insurance requirements.
- ✓ Reduces downtime for gear inspections by over 50%.
- ✓ Provides the customer with improved asset reliability.
- ✓ Providing more equipment availability and a potential recovery of lost production revenue by more than 40%.

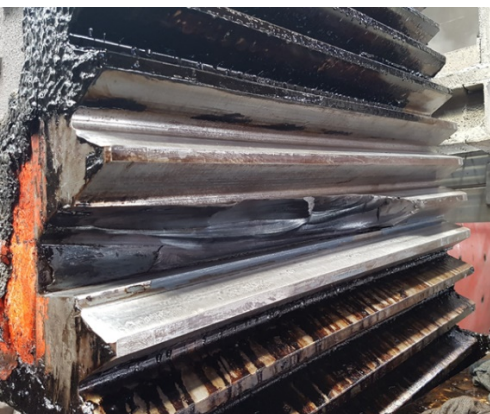

HELPING IN REDUCING THE PROBABILITY OF FAILURES LIKE THIS



Greater Sudbury Economic Development

Sudbury is home to North America's highest concentration of mining expertise. From capital equipment to consumables, engineering to construction and contracting, from mapping to automation and communications – our companies are innovators. More than 300 mining supply and service companies are located with Sudbury. The Greater Sudbury Economic

Development division's job is to make connections that count, whether it's making introductions to local companies, providing market intelligence or providing investment and exporting information. So if you're looking for the latest in mining technology or thinking of establishing a presence in the industry, you should be looking at Sudbury.

Contact:

Scott Rennie

Business Development Officer
Economic Development City
of Greater Sudbury
Canada

Phone: 1-705-918-0855

Email: scott.ennie@greatersudbury.ca

www.investsudbury.ca



THERE IS A WINDOW OF OPPORTUNITY TO ACCELERATE DIGITAL TRANSFORMATION AND ADVANCE THE FUTURE OF WORK.

Source: Deloitte Tracking the Trends 2021



YOU BUILD IT. WE PACK IT.

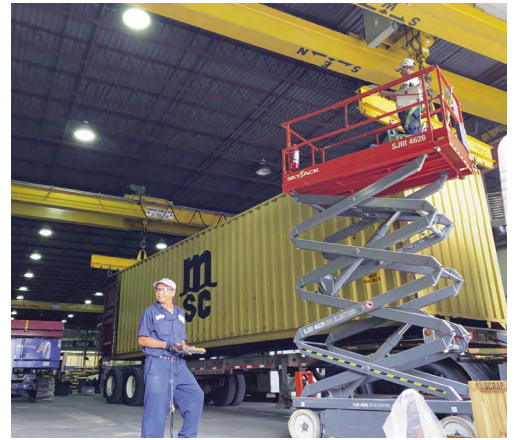

For over 30 years, **TOPAX** has developed solutions for protecting and preserving your valuable mining equipment and supplies. Whether it is preparing your machinery or sensitive components for transport, or guarding them against the elements and ensuring their readiness for use at a later date, we have the expertise and experience to efficiently pack, protect and manage the delivery of your assets.

We secure mining vehicles in sea containers, design/build robust export packing for heavy machinery and reusable supply chain boxes, using lumber from sustainable forestry sources. Anti-corrosion protection with environmentally friendly products minimizes costly damages and ensures that your technology is ready for deployment, when you need it. We aim to deliver your product safely, while reducing our carbon footprint on the earth.

No matter how big or small you build it, **TOPAX will package it, protect it and prepare it for worldwide delivery or long-term storage.**

**WE PROTECT MORE THAN JUST YOUR EQUIPMENT,
WE PROTECT YOUR REPUTATION.**



TOPAX.COM
1-855-55-TOPAX
(1-855-558-6729)

Prospectors & Developers Association of Canada (PDAC)

Prospectors & Developers Association of Canada (PDAC)

PDAC is the leading voice of the mineral exploration and development community. With more than 7,200 members around the world, its mission is to promote a globally responsible, vibrant and sustainable industry that encourages best practices in technical, operational, environmental, safety and social performance. A Board of Directors, 16 volunteer committees, and team of staff carry out the work of

the association. A five-year strategic plan developed by the Board on behalf of members and the industry guides the direction of PDAC. Its goals and objectives centre on the themes of competitiveness, influence, engagement and leadership. Become a member today. PDAC is proud to host the world's premier mineral exploration and mining convention every year. It has attracted more than 25,000 people from 135 countries in recent years, and will be virtual in 2021.

Contact:

PDAC

170 University Avenue, Suite 800
Toronto, Ontario M5H 3B3
Canada
Phone: 1-416-362-1969
Fax: 1-416-362-0101
Email: info@pdac.ca
www.pdac.ca



PROSPECTORS &
DEVELOPERS
ASSOCIATION
OF CANADA

ASSOCIATION
CANADIENNE DES
PROSPECTEURS ET
ENTREPRENEURS

ONE WAY IN WHICH COMPANIES HAVE BEEN LOOKING TO COLLECT SAFETY DATA IS THROUGH WEARABLE TECHNOLOGIES.

Source: Deloitte Tracking the Trends 2021





PROSPECTORS & DEVELOPERS ASSOCIATION OF CANADA

ASSOCIATION CANADIENNE DES PROSPECTEURS ET ENTREPRENEURS



JOIN THE PDAC COMMUNITY TODAY

BECOME A MEMBER OF THE LEADING MINERAL INDUSTRY ASSOCIATION

www.pdac.ca/members
info@pdac.ca

PDAC has remained the leading voice of Canada's mineral exploration and development community since 1932. Our work focusses on strengthening a globally competitive and responsible industry by supporting more than 7,200 individual and corporate members around the world. We undertake advocacy on behalf of Canada's mineral sector, so that our members can focus on achieving their own success.

BENEFITS OF BEING A PDAC MEMBER

- Government advocacy and consultation engagement on behalf of the industry
- Substantial discounts on PDAC Convention registration and Short Courses
- Free member-only webinars
- Access to PDAC Connect, a member-only platform to network, share issues and advance the industry
- Member-only networking events
- Specially designed insurance programs
- Voting rights in board elections and Annual General Meeting
- Access to timely research, reports and toolkits
- Be part of a global community of industry professionals and companies

OUR PRIORITIES FOR CANADA'S MINERAL INDUSTRY



ACCESS TO CAPITAL



ACCESS TO LAND



ACCESS TO SKILLS



CANADIAN INDUSTRY ABROAD



GOVERNMENT RELATIONS

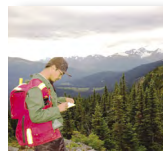

INDIGENOUS AFFAIRS



RESPONSIBLE EXPLORATION

Visit pdac.ca/members or email info@pdac.ca to become a PDAC member today.

PLEASE SEE OUR LISTING ON PAGE 22

Hepburn Engineering Inc.

Hepburn Engineering Inc. (HEI) designs and supplies complete mine hoisting systems with fully integrated electrical controls, digital drives, digital safety monitors, PLC-based operating systems and hoist management software for automated hoisting. The Hepburn Hoist Manager is the most advanced, comprehensive and user-friendly hoist-operating and management system available today. It incorporates advanced fault logging and diagnostics and can be configured to control hoists from a remote location. The new Hepburn Hoist Reporter software provides mine

management with detailed, real-time production reporting, hoist status and searchable fault history using standard web browsers. Through Hepburn Hoist Care, Hepburn engineers can remotely access the hoist controllers and perform remote diagnostics to solve problems quickly. Hepburn electrical controls and Hoist Manager can be retrofitted to existing hoisting plants, as well as incorporated in new hoists to improve automation, performance, productivity, safety and maintenance. See the Hepburn company profile under Hoisting Equipment.

Contact:

John Hepburn

President
73 Six Point Road
Toronto, Ontario M8Z 2X3
Canada
Phone: 1-416-638-4425
Fax: 1-416-638-2070
Email: sales@hepeng.com
www.hepeng.com



Hepburn Ergonomic Hoist Control Console



Hepburn 192-in. Modified Blair Service Hoist during factory assembly. When installed, the hoist will be used to lift the world's largest personnel cage.



Attwell Plastics Corporation



Headquartered in Toronto, Canada and founded in the early 1980s, **Attwell Plastics**

is a leading name in the manufacturing of High-Density Polyethylene products. Our signature blast pipe brand, BP-16, is our solution for stability in blast holes, cuttings and preconditioned columns after drilling. Designed specifically to reduce re-drills, retain drill depths and ensure minimal material fall back. Attwell Plastics is also the manufacturer of **PV-15**, our industry leading brand of HDPE conduit used by some of the world's largest names in the telecom and utility sectors.

Contact

Chris Tilley

National Sales Manager

429 Attwell Drive

Toronto, Ontario M9W 5C4

Canada

Phone: 1-416-675-4311

Email: chris@attwellplastics.com

www.attwellplastics.com

PLEASE SEE OUR LISTINGS ON PAGES 40, 62

VBLTM ValleyBlades

L I M I T E D



LEADING EDGE PRODUCTIVITY, EFFICIENCY AND DURABILITY.

That's what you get when you rely on Valley Blades Ltd. for your mining needs. From blades, cutting edges and ground engaging tools to wear parts and accessories, our commitment to innovation and product development means you get longer lasting, optimal performance on your mining equipment.

Almex Group

Almex Group, also known as Shaw Almex Industries, is not only an industry leader in the design and manufacture of vulcanizers for splicing and belt fabrication but offers a complete family of brands to support your conveyor needs. Almex Group offer the following product and services:

- Almex Heavyweight and Industrial Vulcanizers, control boxes and pumps
- Fusion Systems vulcanizing & repair materials, rubber compounds, cements
- Almex Lightweight offers both shop and field vulcanizers and shop equipment for lightweight belting such as

- finger punches and slitters
- B.A.T tools such as Belt Saws, Cable Strippers, ALMEXPAD tablets and SG1 Control boxes
- EMSYS Belt Asset Management has a full suite of solutions for Rip detection and monitoring
- Votech for dust suppression solutions and pump packs
- Almex Institute offers splice and conveyor training – theory and hands on
- Almex Global Services provides on-site expertise from consulting to belt installation, quality assurance, belt rigging, pulley lagging and equipment audits and certification

Contact:

Susan Moir

Director, Vulcanizer Sales
17 Shaw Almex Drive
Parry Sound, Ontario P2A 2X4
Canada
Email: susan.moir@almex.com
www.almex.com



Rail-Veyor Technologies Global Inc.



Rail-Veyor Technologies Global Inc. is the premier solution for bulk material haulage offering an emission-free, battery-free, and autonomous technology. Rail-Veyor™ offers an innovative material handling system to move industrial, mining, or agricultural products over long distances, complex routes covering difficult surface topographies, and underground mining applications globally. Using our expertise of emerging technologies, we help modern mines to uncover the riches of the earth safely, cleanly, and profitably by engineering efficient solutions. RVTG's hardware

utilizes the best attributes of trucks, rail, and conveyors without diesel emissions, battery charging facilities, and heavy infrastructure. The Rail Veyor system includes uniquely programmed software for each application which allows the system to be **TrulyAutonomous™** and monitored from anywhere. The international headquarters and McCall Testing Facilities are located in Sudbury, Ontario. The Technology Center and United States regional office is located in Houghton, Michigan. Rail-Veyor was awarded First Place at the 2020 Mining Cleantech Challenge.

Contact:

Lisa Youngblood

Executive Director, Marketing & Communications
129 Fielding Road
Sudbury, Ontario P3Y 1L7
Canada

Phone: 1-705-682-0450

Email: lyoungblood@railveyor.com

www.railveyor.com



Motion Metrics

MOTION METRICS
We inspire a new generation of safe, sustainable, and intelligent mining.

| ShovelMetrics™ | LoaderMetrics™ | TruckMetrics™ | BeltMetrics™ | PortaMetrics™ |
|--|---|--|---|---|
| <ul style="list-style-type: none"> Missing Tooth Detection Tooth Wear Monitoring Particle Size Analysis Payload Monitoring Blind Spot Reduction | <ul style="list-style-type: none"> Missing Tooth Detection Blind Spot Reduction | <ul style="list-style-type: none"> Boulder Detection Particle Size Analysis Load Profiling Volume Monitoring | <ul style="list-style-type: none"> Particle Size Analysis Empty Belt Detection Load Profiling Volume Monitoring | <p>Our handheld particle size analysis device uses AI and 3D imaging to eliminate the need for scaling objects.</p> |

Tel: +1 (604) 822-5842 | Email: info@motionmetrics.com | MotionMetrics.com

Contact:

Shahram Tafazoli
Founder and CEO
Email: shahram@motionmetrics.com

Caitlin McKinnon
Marketing Manager
Email: caitlin@motionmetrics.com
Motion Metrics International Corp.
101 - 2389 Health Sciences Mall
Vancouver, British Columbia V6T 1Z3
Canada
Phone: 1-604-822-5842
www.motionmetrics.com

Motion Metrics is a Canadian technology company headquartered in Vancouver that uses its expertise in artificial intelligence and computer vision to inspire a new generation of safe and sustainable mining. With offices on five continents and customers on six, Motion Metrics has been a trusted partner in mining innovation for nearly

two decades. Our products include missing tooth detection for shovels and loaders, tooth wear monitoring for shovels, boulder detection for haul trucks, volume monitoring for conveyor belts and haul trucks, and particle size analysis for shovels, haul trucks, conveyor belts, and in a portable format.



GIVEN THE COMPOUNDING IMPACTS OF CLIMATE CHANGE ACROSS THE ENTERPRISE, THERE IS A GROWING NEED TO SEAMLESSLY INTEGRATE EMISSIONS DATA WITH A COMPANY'S OPERATIONAL AND FINANCIAL DATA.

Source: Deloitte Tracking the Trends 2021



PROVIX Inc.



PROVIX supplies temperature detection cameras for employee screening. PROVIX manufactures, assembles and installs custom camera systems for all mining applications- from wireless remote video systems and safety cameras for mining equipment to loading pocket, chute, breaker, bin and conveyor monitoring. PROVIX can provide cost-effective analogue or digital camera systems that through vision enhancement offer a safer, more productive operating environment. PROVIX remote video systems are

used for scoops, loaders, LHDs and drill rigs. They provide remarkably clear video for mucking, drilling and bolting while allowing operators to remain out of harmsway. Loading pocket cameras transmit video to haul-truck drivers and control-tower monitors. Remote video systems offer extended run times through integrated battery packs or machine-powerconnections. Wireless inspection camera systems can include integrated recording capability and enhanced lighting for stope, brow, pass, bin and drift inspection while viewed from the safe operator station. PROVIX also supplies broadband back-up alarms and LED and HID equipment lighting from the worlds finest manufacturers. PROVIX distributes the RESCOM cabled communication for mining, tunneling and mine rescue. Wisdom Worlds brightest cap lamps.

Contact:

Karly Winfield

Email: karly.winfield@provix.net
6436 Highway 89 East
Alliston, Ontario L9R 1V2
Canada
Phone: 1-705-434-0253
Toll Free: 1-888-434-0253
Email: sales@provix.net
www.provix.net
www.EquipmentLight.com



RWDI

RWDI's 45+ year history includes a portfolio of unparalleled experience gained from thousands of projects around the world. Our dedicated team of experts have achieved the reputation that has made RWDI a trusted partner in the mining and other industrial sectors. We help clients assess environmental impacts at the planning, operations and decommissioning stages of projects. Our project teams include meteorologists, engineers, climatologists, experts in numerical modelling,

IT, acoustic and source testing specialists, and other scientists. Modelling work is supported by in-house, research-caliber, high-performance computing services; wind tunnels offer simulations to solve even the most complex wind engineering challenges. Our project teams draw collaboratively on these exceptionally deep resources to help our clients find creative, optimized solutions for their most demanding climate engineering and environmental challenges.

Contact:

Monika Greenfield, M.Sc.
 Strategic Director – Mining RWDI
 600 Southgate Drive
 Guelph, Ontario N1G 3W6
 Canada
 Phone: 1-705-280-7693
 Email: monika.greenfield@rwdi.com
www.rwdi.com



MINERAL DEVELOPMENT CYCLE

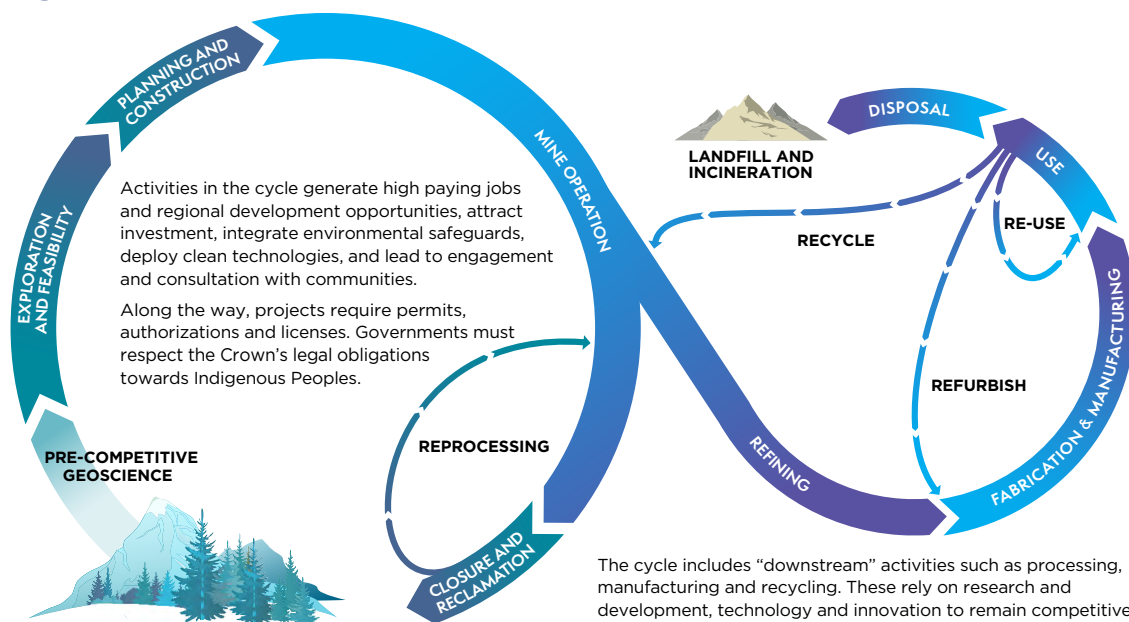

Source: Canadian Metals and Minerals Plan (CMMP) 2020



Intelline Inc.

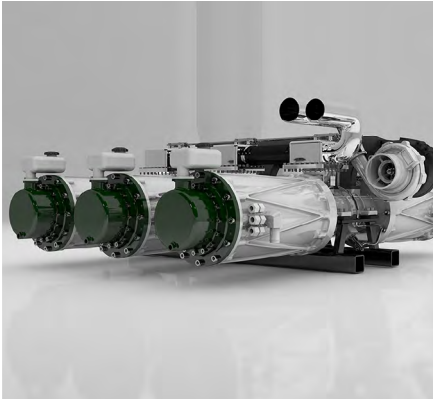

Intelline designs and manufactures industrial generators that use up to 40 percent less fuel. Our Modular Linear Generator (MLG) greatly improves efficiency

over traditional generators by minimizing sources of loss, while retaining a simple and reliable piston-engine architecture that customers can depend on. The MLG design offers unprecedented flexibility for a generator solution, with fuel options from traditional diesel and natural gas, to modern sources such as biofuels and synthetic fuels. The modular approach allows for easier service, built-in redundancies, and very effective load matching to minimize fuel consumption and emissions. We are based in Kitchener, Ontario.

Contact:

Kyle Faller

Founder & CEO
151 Charles Street West, Suite 199
Kitchener, Ontario N2G 1H6
Canada
Phone: 1-548-483-5599
Email: kylefaller@intelline.ca
www.intelline.ca



LESS PARTS
LESS FUEL

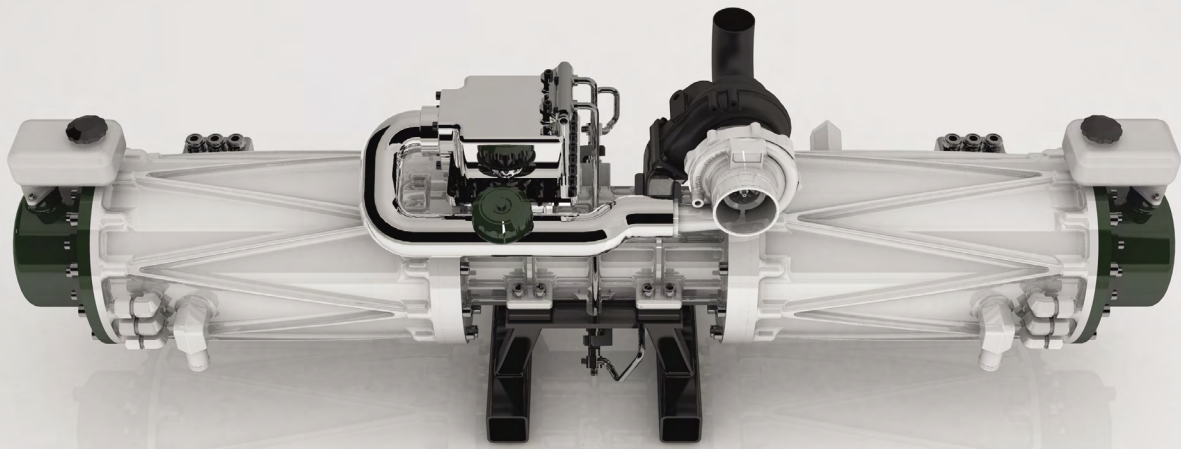

The **Modular Linear Generator**

Learn how our unique diesel generators use up to 40% less fuel at

intelline.ca

APPROACH TO ACHIEVING THE VISION

The Plan includes six strategic directions:



Canada's business and innovation environment for the minerals sector is the world's most competitive and most attractive for investment



Increased economic opportunities for Indigenous Peoples and supporting the process of reconciliation



The protection of Canada's natural environment underpins a responsible, competitive industry. Canada is a leader in building public trust, developing tomorrow's low-footprint mines and managing the legacy of past activities



A modern and innovative industry supported by world-leading science and technology—across all phases of the mineral development cycle



Communities welcome sustainable mineral development activities for the benefits they deliver



A sharpened competitive edge and increased global leadership for Canada

Source: Canadian Metals and Minerals Plan (CMMP) 2020



Adria Power Systems



With more than 25 years of experience in the design and manufacture of distribution and electrical power products in the industrial, commercial and mining sectors, **Adria Power Systems®** is a leader for whom its loyal

customers place their entire confidence in the implementation of the best possible solutions adapted to their own situation. The product list includes electrical substations, portable and mobile, for underground and open pit mines, mine power centers, industrial and mining switchgears, medium voltage junction boxes, only to name a few. Adria Power Systems® is a reference for charging systems for mining vehicles operating with high capacity power batteries. This has positioned Adria as a leader in the development of this type of charger.

Contact:

Jean-Francois Couillard

President

1250 rue Saguenay

Rouyn-Noranda, Québec J9X 7C3

Canada

Phone: 1-819-797-5881, ext. 237

Email: jfcouillard@adria-corp.com

www.adria-corp.com



ELECTRICAL EQUIPMENT



2020
REPORT ON BUSINESS
CANADA'S TOP GROWING
COMPANIES



SUBSTATIONS



**CHARGING SYSTEMS
AND A LOT MORE!**



JUNCTION BOXES

ADRIA POWER SYSTEMS®

1250, rue Saguenay Rouyan-Noranda, Qc, Canada, J9X 7C3

info@adria-corp.com www.adria-corp.com +1 819-797-5881

Mine Cable Services Corporation

Mine Cable Services Corporation (MCS) designs and manufactures medium voltage cable connection systems, repair equipment and handling systems, offering a full range of cable couplers, including 5 kV, 8 kV, 15 kV and 25 kV, compatible with all couplers of North American design. MCS junction boxes and cable posi-clamp systems have been designed to meet the rigours of mine site environments, including dust and moisture. MCS' Cable Vulcanizing Systems include portable, hydraulic and oven repair equipment with the use

of Teflon-coated cable moulds or pressure cooking tapes to produce flexible and waterproof cable repairs. MCS also provides a complete line of cable repair materials, including Neoprene, Hypalon and TPU jacketing material. Cable handling and safety equipment consists of cable reelers, stands, safety locks, crossover systems and strain relief clamps. With facilities in Canada and a network of distributors in Latin America, Europe and Australia, MCS provides cable connections, repair and handling solutions to clients worldwide.

Contact:

7731 - 16th Street NW

Edmonton, Alberta T6P 1M1
Canada

Phone: 1-780-439-1113

Toll Free: 1-800-663-2889
(U.S. & Canada)

Fax: 1-780-439-4443

Email: sales@minecableservices.ca

www.minecableservices.ca

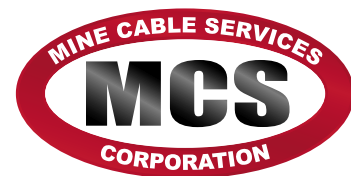

THE CANADIAN MINING INDUSTRY IS PROVIDING GLOBAL LEADERSHIP THROUGH ITS TOWARDS SUSTAINABLE MINING[®] PROGRAM TO FOCUS ON ENABLING MINING COMPANIES TO MEET SOCIETY'S NEEDS FOR MINERALS, METALS AND ENERGY PRODUCTS IN THE MOST SOCIALLY AND ENVIRONMENTALLY RESPONSIBLE WAY.

Source: Facts & Figures 2020, The Mining Association of Canada



ECO Technologies

ECO Technologies is an environmental services company specializing in custom-designed dredging interventions for harsh industrial environments. Our clients depend on us to protect what matters most to them. Whether it be their reputation, their environmental record, their safety record, their uptime or their bottom line, our team of innovative dredging specialists gets the job done quickly, safely, and with minimal

environmental impact. We are an industry leader with a reputation for efficient, timely, cost-effective results that reflect our expertise and our dedication to client satisfaction, while boasting the highest of safety and professional standards. Dredging tailings ponds and industrial lagoons represent a cost of doing business; ECO Technologies can help you keep costs low while ensuring the job gets done right.

Contact:

Marc Maurice

27 Industriel Boulevard, Unit 120
Caraquet, New Brunswick E1W 0A2
Canada
Phone: 1-506-726-6073
Fax: 1-506-726-6044
Email: marc.maurice@ecotec.ca
www.ecotec.ca



PROTECT

what matters

MOST



Protect
uptime



Reduce
operating costs



Avoid
shutdowns

Protecting your uptime protects your bottom line.

ECO Technologies operates the most versatile and productive fleet of amphibious dredges in Canada, helping to manage your tailings ponds, your water supply, **reduce your operating costs** and **avoid costly shutdowns**.

Contact Us Now
ecotec.ca

1 888.356.0111

info@ecotec.ca

ECO
TECHNOLOGIES

Titan Environmental Containment



Titan Environmental Containment specializes in the supply and installation of high-quality geosynthetics and specialty engineered construction products for mine infrastructure. From tailings ponds to caps, tunnels, channels and haul roads Titan provides innovative and cost-effective solutions for a range of mine projects; including Concrete Canvas®, a flexible concrete filled geosynthetic that hardens on hydration to form a

thin durable, waterproof layer. This eco-friendly alternative to concrete is cost-effective, easy and ideal for mine channel lining and mine vents. Titan is also revolutionizing the mining industry with their Mine-Shield Grid™, an advanced line of high-strength polymer biaxial geogrid developed as a load bearing alternative to steel/metal mesh for soft and hard rock underground mining applications. Lighter than steel and metal mesh, Mine-Shield Grid™ improves safety, decreases mine operating costs and speeds up development work. With locations across Canada and comprehensive installation, project management and technical expertise Titan excels at working with you in the consultation, planning and execution phase of any project. Let Titan help you save money and reduce your project's carbon footprint. Call or email us today!

Contact:

Sam Bhat, M.Eng (Tech Mgt), MIGS
Vice President, Global Business Development and Chief Technology Officer, Geosynthetics
Email: sam@titanenviro.ca

Juice Lambert
Vice President, Sales
Email: juice@titanenviro.ca

Head Office:
777 Quest Boulevard
Ile des Chenes, Manitoba ROA OT1
Canada
Phone: 1-204-878-3955
Toll Free: 1-866-327-1957
Fax: 1-204-878-3980
Email: info@titanenviro.com
www.titanenviro.com



THE PROPORTION OF INDIGENOUS WORKERS IN THE MINING INDUSTRY IS WELL ABOVE THAT OF THE REST OF THE CANADIAN WORKFORCE.

Source: Facts & Figures 2020, The Mining Association of Canada



Aspen Custom Trailers



Contact:

Wayne Rootsart

Mining Products Manager
391481 Avenue
Leduc, Alberta T9R 0C3
Canada
Phone: 1-780-980-1925
Toll Free: 1-800-832-9410
www.aspentrailer.com



Since 1979, the **Aspen** name has long stood for superior design, quality, and durability. What makes us different is our approach to reliability and product longevity. Aspen understands that mining is a tough way to make a living; commodity prices cycle up and down, budgets are tight, the conditions are often extreme and operating targets must be met. Aspen's mining trailers are designed to work with your existing equipment, and they do the job they are designed

to do; every single day. Building mining trailers for use around the world is certainly some of the most challenging work Aspen takes on. We have proven our ability to supply some of the most demanding mines with both bulk haulers and site transporters. Aspen designs a specific line of products for our mining customers, ranging from 60 ton bulk haulers to 350 ton single axle lowbed trailers with tow/retrieval arms for 400 ton class haul trucks.



Eutectic Canada Inc.

Eutectic Canada Inc. For over 100 years, Eutectic Castolin has been delivering engineered wear protection and management solutions designed to extend service life and performance of key components and equipment, increasing productivity and reducing operating costs. Eutectic offers comprehensive, long-lasting solutions to the mining industry worldwide using advanced welding, brazing, thermal spray, polymer and wear plate technologies. Our turnkey maintenance and surfacing solutions can be carried out onsite or in our Service Centers.

Eutectic **CastoDur Diamond Plates**® (CDP®) wear liners have a long track record and proven performance in the protection of mine skids, truck bodies, buckets and chutes. **Eutectic CastoTubes**® – internally hardfaced pipes with engineered alloys – with a choice of connecting systems, are the optimal cost-effective solution for paste backfill lines. As world leaders in surface protection and asset efficiency, we are committed to creating the best-value solution for each individual customer using the latest technologies, enhancing service life and bottom line.

Contact:

Atacan Oner

Industry Segment Manager, Mining
Phone: 1-800-361-9439

Canada East

428 rue Aimé-Vincent
Vaudreuil-Dorion, Québec J7V 5V5
Phone: 1-514-695-7500

Canada Central

7065 Tranmere Drive, Suite 6
Mississauga, Ontario L5S 1M2
Phone: 1-905-676-1969

Canada West

7722 - 69th Street
Edmonton, Alberta T6B 2J7
Phone: 1-780-465-8073
Email: eutectic@eutectic.com
www.eutectic.ca



Valley Blades Limited

Valley Blades Limited, ISO 9001:2015 certified, manufactures replacement wearing edges for earth and snow removal equipment, including bulldozers, road graders, loaders, scrapers, excavators and snowplows. These wearing edges are manufactured using computer-assisted technology to rigid specifications that meet or exceed those set by the original equipment manufacturer. Since it began in the early 1960s, Valley Blades Limited has grown into a world supplier of

replacement wearing edges and has built a strong dealer network that supplies competitively priced, quality products and reliable service backed by an extensive inventory. Valley Blades Limited manufactures replacement wearing edges for Caterpillar, Komatsu, Deere, Case, Terex, Volvo and more, and has manufacturing facilities located in Waterloo, Ontario and Edmonton, Alberta, to serve the mining industry nationwide and customers around the world.

Contact:

Bruno Montesano Jr.
Sales Manager
Email: bruno@valleyblades.com
435 Phillip Street
Waterloo, Ontario N2L 3X2
Canada
Phone: 1-519-885-5500
Toll Free: 1-800-461-1824
Fax: 1-519-746-2780
Email: sales@valleyblades.com
www.valleyblades.com



PLEASE SEE OUR LISTING ON PAGE 26

The advertisement features a dark background with a pattern of light-colored hexagons. On the left, there are three images: a 3D rendering of a conveyor system component, a close-up of a red conveyor belt with a metal sensor, and a mechanical assembly with a green sensor. A white paper graphic with a blue binder clip is positioned in the lower-left corner, containing the text 'bam' and a description of the solution. On the right, the 'EMSYS' logo is prominently displayed in large, white, bold letters, with 'TECHNOLOGICALLY ADVANCED' written below it. Underneath the logo is the text 'RIP DETECTION & MONITORING SOLUTIONS'. A bulleted list of features is provided, followed by contact information for requesting more information or a webinar. The Almex Group logo and website are located in the bottom right corner.

EMSYS
TECHNOLOGICALLY ADVANCED
RIP DETECTION & MONITORING SOLUTIONS

- LSRS - Loop Sensing Receiver w/Smartwire
- WSR - Width Sensing Receiver
- BGS - Belt Steering Gear • BeltGard 3.0
- SB-BW - Belt Scale • Vision

To request more information or to arrange a webinar for an overview of the EMSYS BAM Solution, Call 1.800.977.5423 or email info@almex.com

almex
verb: (n. acronym)
An investment in the protection, control and monitoring of a conveyor system to achieve a greater conveyor life, higher reliability and ultimately ensure better material production throughput and output.

ALMEX GROUP | almex.com

GEM Systems Inc.



GEM Systems Inc. is a world leader in high-precision magnetometers, gradiometers and magnetic sensors for mineral/oil exploration, environmental, engineering, UXO applications and earthquake research. GEM Systems pioneered the most precise optically pumped potassium magnetometer and the high-speed Overhauser. Ground systems include magnetometers and gradiometers available in walking mode and featuring integrated GPS and optional VLF-EM for shallow resistivity mapping. Airborne systems include magnetometer, VLF sensor(s) and towed bird

systems for single sensor and gradiometer (vertical and/or horizontal configuration) applications. Earth monitoring systems include the dIdD vector magnetometer for measuring precise changes in Earth declination and inclination, and the Super Gradiometer for measuring very subtle gradient field changes. UAV solutions include the ultra-lightweight potassium high-precision UAV magnetometer (DRONEmag™) in addition to the super-lightweight Cardinal, AirBIRD, AirGRAD and the new AirVLF (UAV VLF-EM) towed systems. GEM also manufactures a stabilized magnetic field system for experimentation and calibration. Systems are turnkey, reliable, available with various options and configurations and a three-year warranty.

Contact:

Shawn E. Kovacs, Ph.D., M.B.A., G.I.T.
Geoscientist, Sales and Marketing Manager
Email: Shawn.kovacs@gemsys.ca

Geraldo Pinto
International Business Development Manager
Email: Geraldo-pinto@gemsystems.ca
135 Spy Court
Markham, Ontario L3R 5H6
Canada
Phone: 1-905-752-2202
Fax: 1-905-752-2205
Email: info@gemsystems.ca
www.gemsystems.ca



Since 1980
Leading the World of Magnetics

THE MINING SECTOR IN CANADA IS ONE OF THE FEW SECTORS THAT CONSISTENTLY MAKES A POSITIVE CONTRIBUTION TO CANADA'S BALANCE OF TRADE.

Source: Facts & Figures 2020, The Mining Association of Canada



Terraplus

Terraplus has been in business for more than 30 years and has grown to become one of the world's largest suppliers of geophysical instruments. We have a wide range of products available for sale, which employ a variety of geophysical methods, including:

- Borehole Logging
- Conductivity Meters
- Electromagnetics (EM)*
- Ground Penetrating Radar (GPR)*
- Induced Polarization (IP)
- Magnetic Susceptibility & Physical Properties

- Magnetometers* & VLF*
- Resistivity Meters & ERT Systems
- Scintillometers & Spectrometers*
- Seismic

*Also available in UAV and/or airborne platforms

We also have a comprehensive rental inventory along with an in-house technical department that can provide training and support, making us a one-stop source for your geophysical needs. Not sure which equipment is best suited for you? Visit our website or contact us to learn more.

Contact:

Claude Meunier

President

120 West Beaver Creek Road, Unit 15
Richmond Hill, Ontario L4B 1L2

Canada

Phone: 1-905-764-5505

Fax: 1-905-764-8093

Email: sales@terraplus.ca

www.terraplus.ca

Terraplus
empowering discovery

PLEASE SEE OUR LISTING ON PAGE 27

Profitable.
Clean.
Safe.

**Modern mines seek to uncover the riches of the earth:
Safely, Cleanly and Profitably.**

Rail-Veyor is a material haulage solution that combines the best of conventional haulage methods and improves operations for both surface and underground applications. ■ With Rail-Veyor's TrulyAutonomous™ system, operators can be removed from hazardous areas to monitor remotely. ■ There's no diesel exhaust or batteries to charge. ■

The carbon footprint of the Rail-Veyor system is measurably lower than other haulage solutions, resulting in a lighter environmental impact. ■ Rail-Veyor optimizes material transport to enhance profitability. ■

Quickly deployed, relocated or extended, Rail-Veyor is adaptable to any terrain and cuts operating costs.

Move your mining operation into the future with

Rail-Veyor®

Website: www.RailVeyor.com ■ YouTube: [@RailVeyor](https://www.youtube.com/@RailVeyor) ■ Email: info@railveyor.com

Horne Conveyance Safety Ltd.

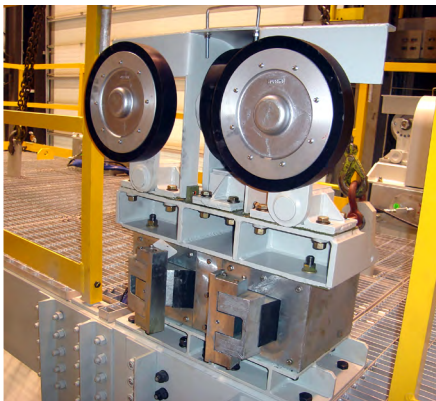

Engineered Safety Solutions in Mine Hoisting & Conveyance.

Horne Conveyance Safety Ltd. is a world leader in mine cage- and skip chairing and has extensive experience in impact energy absorption. The company's **Levelok cage- and skip chairing systems**, continuously developed, and tested for more than 30 years, overcome rope-stretch problems when hoisting heavy materials and ore in underground mines. The Levelok system can be operated with steel and wooden shaft guides. The Emergency Fall Arrest System (**E-FAS**) provides safe deceleration in

the event of an uncontrolled fall of a mine cage. Horne also supplies the **Technogrid** system, a well-engineered solution in a variety of applications, such as safely arresting mine cages in over-wind conditions in a head frame, or for counterweights on conveyor systems, impact absorption for railway rolling stock or potentially on roadway guardrails and other areas where sudden unexpected impact absorption needs to be applied to avoid serious damage or injury. Horne is also a distributor for Reng Gopro **Cage and Skip Guide Rollers**. This multi-purpose, bracketed, solid wheel guide roller system consistently outperforms pneumatic tire type design, lending to a more stable ride of the conveyance extending guide roller life resulting in operational cost savings. Our clients include some of the world's largest and most reputable mines with more than 100 installations in Canada, South Africa, the U.S.A., Australia, Mongolia, UK, South America, India and more.

Contact:

Annelea Blignaut

Vice President

P.O. Box 35090 RPO Essa Road

Barrie, Ontario L4N 5Z2

Canada

Phone: 1-705-791-4167

Office: 1-705-791-8963

Email: annelea@hornecs.com

www.hornecs.com



TopVu Ltd.

A Technology manufacture focused on Tracking & Location Systems for mining. At the core of our innovations is **TopVu's** 2nd Generation software offering a web based software and a REST API platform to integrate our product. The smart eTagboard provides digital records of tagboard attendance also improving mine rescue activities. When the eTagBoard is combined with TopVu's checkpoint tracking (RFID or BLE), Gen.2 software can deliver unprecedented safety benefits

eliminating tagboard incidents and improving accountability. Gen.2 also integrates RFID turnstiles to document workers on your property and Muster Tap Stations for assembly points. Production & Geology can optimize their throughput by deploying TopVu's **Ore Tracking** system to analyze the muck's origin, type (**Ore vs. Waste**), retention time, and receive alerts when material is detected on the wrong path. Contact us to schedule your interactive video discovery session.

Contact:

Yvan Brulé
Business Developer
Sudbury, Ontario
Canada
Phone: 1-705-419-2555
Email: sales@topvu.ca
www.topvu.ca



MINING LOCATION SERVICES

TopVu's web-based, REST API platform integrates multiple tracking systems to improve

- mine rescue
- safety systems
- digital records
- production efficiencies

Phone: 705-419-2555 • Email: sales@topvu.ca
Visit: www.topvu.ca

DIGITAL/SMART TAGBOARD

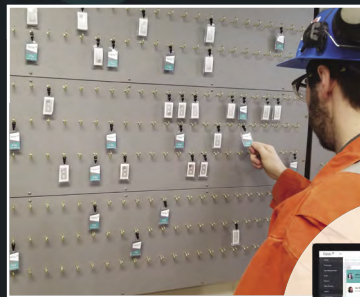

PROPERTY ACCESS



CHECKPOINT TRACKING

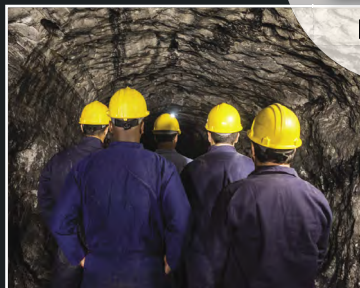

ORE TRACKING



Enterprise Software



Hepburn Engineering Inc.

Hepburn Engineering Inc. (HEI) designs and supplies complete mine hoisting systems for applications from shaft sinking up to the largest production requirements: single drum, double drum, Blair, friction (Koepe) hoisting plants with integrated electrical controls, digital drives, safety monitors, PLC-based operating systems and the powerful Hepburn Hoist Manager software. Hepburn Hoist Reporter software provides web-accessible, real-time hoist status and production reporting. HEI engineers provide efficient, functional designs and fully integrated hoisting solutions

with single-source responsibility. HEI supplies stage winches, sheaves, automated weighing systems and new braking systems, retrofit digital controls, engineering, hoist rebuilding and field services for existing hoists. HEI has an extensive installed hoist population and strong international presence maintained through local representatives supported by an effective service organization and remote access Hepburn Hoist Care. HEI owns the mine hoist technology of Canadian Ingersoll Rand (CIR), Westinghouse Canada, FH&B and Ottumwa, and provides OEM parts and service worldwide.

Contact:

John Hepburn

President
73 Six Point Road
Toronto, Ontario M8Z 2X3
Canada
Phone: 1-416-638-4425
Fax: 1-416-638-2070
Email: sales@hepeng.com
www.hepeng.com



Hepburn 160-in. Double Drum Production Hoist.



Hepburn 192-in. Modified Blair Service Hoist during factory assembly. When installed, the hoist will be used to lift the world's largest personnel cage.



American Biltrite Ltd.



GUARD-RITE: Engineered Rubber Linings. GUARD-RITE is American Biltrite's distinctive product line developed to meet the critical challenges of the rubber lining market. Choose from several polymers to cover an array of cold bond lining applications. Discover our premium textured bonding layer, adhesive-ready with no buffing required.

Simplify your processes with one installation procedure and one adhesive system for any of our eight GUARD-RITE products. Proven solutions to extend the service life of critical equipment and drastically reduce expensive down-time. American Biltrite is a global company with over 100 years of experience as leaders in the rubber industry. A family owned company since 1908, our North American manufacturing feeds our ten warehouses throughout the USA and Canada. Fast service for emergency requirements with impressive lead times. Value added services include product selection assistance, technical advice, trouble shooting, and industry-leading Customer Service. Please contact us for your free GUARD-RITE catalog today.

Contact:

Jean Vavrek

Market Manager
American Biltrite
200 Bank Street
Sherbrooke, Québec J1H 4K3
Canada

Phone: 1-450-543-0795

Fax: 1-819-829-3360

Email: jvavrek@american-biltrite.com

www.american-biltrite.com



AmericanBiltrite
IndustrialRubber

VALUE OF MINING IN 2019:

Canada-wide:

\$48.1 billion

TOP 4 PROVINCES:

1. QUEBEC: **\$10.8 billion**
2. ONTARIO: **\$10.7 billion**
3. BRITISH COLUMBIA: **\$8.8 billion**
4. SASKATCHEWAN: **\$6.7 billion**

Source: Facts & Figures 2020, The Mining Association of Canada



Boundary Equipment Co. Ltd.

Open-pit mining's single source for critical equipment components and maintenance services.

Services

- Manufacturing
- Repair & Rebuild
- Custom Design & Engineering
- Reverse Engineering

Capabilities

- Cast Components
- Undercarriage
- Gear Manufacturing
- Gearbox Refurbishment
- Hydraulic Cylinders

Areas of Expertise

- Hydraulic Machines
- Rope Shovels
- Drills
- Apron Feeder Pans
- Mineral Processing
- Draglines

Featured Innovations

- CAT 7495 Undercarriage / Lowerworks
- Point Sheave
- Padlocks
- Posikeeper™
- Track Shoes

Boundary Equipment specializes in Aftermarket Mining Replacement Parts. In collaboration with our affiliates ISS Mine Safety, United Gear, and Bridge Machine, we offer a single source for design, manufacturing, replace and repair, or custom solutions for critical mining equipment parts and components. Our ISO 9001:2015 certified quality management system and comprehensive service approach help ensure our customers expectations are met or exceeded every time. For projects done right - the first time, contact Boundary.

Contact:

Alex Tutschek

President
10740 - 181 Street NW
Edmonton, Alberta T5S 1K8
Canada
Phone: 1-780-666-7517
Fax: 1-780-484-1299
Email: boundary@boundaryequipment.com
www.boundaryequipment.com



Open-pit mining's single source for critical equipment components & services.

MANUFACTURE | REPAIR | REFURBISHMENT | CUSTOM



Canadian Wear Technologies



Using its own foundry,

Canadian Wear Technologies™ manufactures Abreco® laminated white iron materials that are engineered to outperform other materials on the market today. A composite of extremely wear-resistant, cast white iron 700+ BHN (64 HRC) is metallurgically bonded to a mild steel backer

plate providing weld-ability and impact resistance. Canadian Wear Technologies serves mining operations throughout the Americas and Europe by manufacturing ready to install wear parts or custom castings. Our A-Team of industry professionals work to optimize uptime on fixed plant material handling equipment. Exclusive to Canadian Wear Technologies, the Abreco Wear System® is proven world-wide to significantly increase operator safety and production uptime in primary crushing circuits in all types of hard rock mining. AbrecoPipe® is the world's first and only centrifugally cast, bimetallic pipe for severely abrasive slurry that can be formed into long-radius elbows.

Contact:

Keith Holbrook

President

Email: kholbrook@canadianweartech.com

Bill Lee

Vice President

Email: blee@canadianweartech.com

675 Brook Road North

Cobourg, Ontario K9A 4J8

Canada

Phone: 1-905-373-9327

Fax: 1-905-373-4172

Email: info@canadianweartech.com

www.canadianweartech.com

Canadian
WEAR™
TECHNOLOGIES

CANADA'S MINERAL-PROCESSING FACILITIES FAST FACT:

QUEBEC: **9** smelters, **4** refineries, **2** secondary smelters

ONTARIO: **2** secondary smelters, **3** refineries, **3** smelter/refineries, **1** conversion facility

MANITOBA: **1** smelter/refinery, 1 refinery

ALBERTA: **1** refinery

BRITISH COLUMBIA: **1** smelter, **1** secondary smelter, **1** smelter/refinery, **1** processing plant

NEWFOUNDLAND AND LABRADOR: **1** refinery

Source: Facts & Figures 2020, The Mining Association of Canada



Heath & Sherwood



To celebrate their partnership, Consep presented Heath & Sherwood with a statue of an ice hockey player completely made of stainless steel, affectionately named Sydney T Kirkland and are glad to now have him in the "town that built NHL!"

Heath & Sherwood has been a supplier of quality products to the mining industry for 90-plus years. The company is known for close contact with customers and prides itself on client service that adapts the product line to specific customer needs. Heath & Sherwood supplies a complete line of standard and

custom-designed samplers used for feeding process control analyzers, metallurgical accounting and inventory control requirements. A variety of samplers for pipes (gravity or pressurized flow), high-flow launders, conveyors, chutes and bulk containers are available. When following good sampling, profits are protected within the process. Also in the product line is smelter equipment, including the Gaspé Puncher, Gaspé, Tuyère Automation Systems, Tuyère Silencers, Tuyère Pyrometers and Tuyère Line Refractory Drills. Used in most copper and nickel smelters, Heath & Sherwood's smelting equipment helps customers maximize their smelter process with quick payback. Check out the new bulk material handling and sampling equipment now offered after the recent expanded partnership with CONSEP Pty Ltd. of Sydney, Australia.

Contact:

Phillip A. Cancila

P.O. Box 340

Kirkland Lake, Ontario P2N 3J2

Canada

Mobile: 1-905-302-6684

Phone: 1-905-275-2906

Fax: 1-905-275-3357

Email: philc@heathandsherwood.com

www.heathandsherwood.com



McCloskey International



McCloskey International leads the screening and crushing industry with a complete line of equipment including crushers, screeners, stackers, and washing systems. With a worldwide reputation for high performance products that have introduced many of today's key mobile screening and

crushing innovations, McCloskey is sold globally through its network of authorized dealers. Since 2019, McCloskey is a part of Metso Corporation, a world-leading industrial company offering equipment and services in the mining, aggregates, recycling and process industries.

Contact:

Worldwide Headquarters

John O'Neill
 Vice President, Sales
 1 McCloskey Road
 Keene, Ontario K9J 0G6
 Canada
 Phone: 1-705-295-4925
 Toll Free: 1-877-876-6635
 Fax: 1-705-295-4777
 Email: sales@mccloskeyinternational.com
 www.mccloskeyinternational.com



SAFETY ANALYTICS: DATA SOURCING

Building on the core data contained by health and safety systems, policies, and procedures, safety analytics relies on the integration of disparate data sets to deliver deeper insights.

INTERNAL DATA SOURCES

Existing safety management data and enterprise systems:

- Safety standards, policies, and procedures
- Incident data, safety audits, and field observations
- HR, timekeeping, training, operations, and maintenance data

TELEMATICS AND WEARABLES

Integrated with technology devices that track data and information related to environmental and physical factors of the machine/person and its surroundings:

- Personnel vitals and environmental monitoring
- Geolocation and movement tracking
- Onboard equipment system alerts and condition-based monitoring
- Equipment operations metrics

EXTERNAL DATA SOURCES

Open source and other external data sources broaden the perspective beyond the organization:

- Industry standards, research, and benchmarks
- Weather, demographics, and geospatial data
- Social media

Source: Deloitte Tracking the Trends 2021



Green Canpump Inc.

As a Canadian company **Green Canpump** is a member of vast industry group with more than thirty years of experience in high pressure pumps for mining, oil & gas, agriculture, misting, cooling & fogging around the globe. As the North American distributor of Bertolini Pumps, we seek to present exceptional services and value to customers. In Mining, light weight aluminum head pumps are used to transfer water over long distances or through elevation. Blowout Preventers (BOP) in oil and gas industry, Sewer jetting systems to clean sewer/drain lines.

Use of high pressure pumps is at the heart of these systems. Green Canpump specializes in sale and distribution of these piston pumps. Broad inventory of pumps, spare parts and accessories. The origins of Bertolini as a parent company dates back to 1918. Research and development is at the core of manufacturing with state of the art techniques to ensure the highest quality and precision. Fully automated warehouse, ultra modern assembly lines and latest generation machine tools based in Italy.

Contact:

Ali Sabzevari

Managing Director
2501 Steeles Avenue West, Unit 2
Toronto, Ontario M3J 2P1
Canada
Phone: 1-416-250-7867
Toll Free: 1-833-787-7867
Email: Info@canpump.com
www.canpump.com
www.Bertolinipumps.ca



Green Canpump inc.

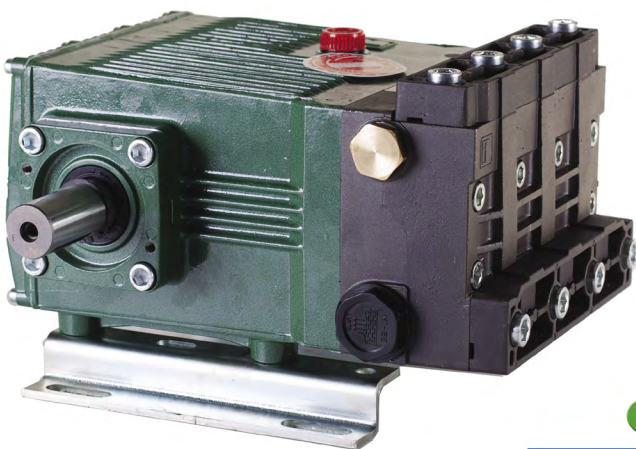

HydroTech Mining Inc.

HydroTech Mining specializes in design, production and sales of pumping and dewatering systems for the mining industry. Whether it's for clear or slurry dewatering, we can help you. We offer a wide array of high-performing submersible dewatering pumps and systems designed for all types of mining operations. Customer service is always a core priority, our sales team makes a point to respond to calls 24 hours a day, 7 days a week. We are

known in the mining industry for our rigor and availability. This is one of the reasons why many are turning to us to develop and carry out their projects, simple or highly complex. We offer a rich array of skills and knowledge acquired by people who understand your needs and are committed to find innovative dewatering solutions adapted to each context and built-strong products to remain effective throughout the life cycle of your operations.

Contact:

Cheyne Poirier

Business Development Manager
297, 7^e rue

Val-d'Or, Québec J9P 0G5
Canada

Phone: 1-819-874-4499, ext. 201

Fax: 1-819-874-0259

Email: cpoirier@hydrotechmining.com

www.hydrotechmining.com



PLEASE SEE OUR LISTING ON PAGE 29

PROVIX.NET NOW I CAN SEE!

DETECT Abnormal Temperatures in Seconds

HIKVision Dual Lens Temperature Detection Camera Systems

The HIKVision Temperature Screening Thermographic Camera is designed to detect elevated skin surface temperatures with high accuracy in real-time. It can be used primarily in common areas to screen multiple people simultaneously in mines, factories, shared spaces, cafeterias, office buildings, hospitals, public transport stations and anywhere indoors. **Health Canada Certified!**

PROVIX 7-inch Facial Recognition Camera

The PROVIX COVID Camera is equipped with an Infrared camera and a built-in skin temperature detection module, which can rapidly determine a person's temperature when standing in front of the camera. The COVID Camera can also authenticate an individual with facial recognition software to grant or deny access.

Both systems fully Networkable with IVMS software!

Over 2,000 Provix thermal temperature cameras in use



Contact:

Karly@Provix.net
+1(519) 803-5805

www.covidcamera.com

Coding Metrology Inc.

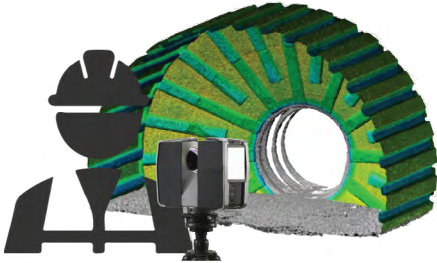

Coding Metrology Inc. is a Canadian owned Metrology services company offering premium laser scan and analysis services. We specialize in grinding mill and crusher wear component inspection for the mining industry. Our expertise is in wear tracking and analysis of SAG, Ball, and Rod mill liners as well as gyratory crusher liners. We virtually and remotely train technicians to scan mills in a safe and comprehensive manner to reducing staff and shut-down time of operations; having done so all over the world.

Laser scanners capture millions of measured points, data we analyze using premium metrology software and in-house developed methods and code to generate detailed reports. Each report is compiled and analyzed by our team to provide valuable feedback about operations and efficiency. Our common deliverables are complete reports and recommendations that can be shared with team members from executives, metallurgy professionals, and technicians. The use of state-of-the-art terrestrial scanning data and in-house developed automation technology is an integral part of the business. Implementation of our quality control and assurance program is also utilized for a high-quality product. We also offer services to the Architecture, Engineering, and Construction (AEC) industry.

Contact:

Tony Facciolo

President

20-120 Woodstream Blvd., Suite 105

Woodbridge, Ontario L4L 7Z1

Canada

Phone: 1-647-212-6710

Email: Tony.facciolo@codingmetrology.com

www.codingmetrology.com



ACCORDING TO NATURAL RESOURCES CANADA, THE MINING INDUSTRY INDIRECTLY EMPLOYED AN ADDITIONAL 327,000 INDIVIDUALS IN 2019, BRINGING TOTAL EMPLOYMENT TO 719,000 JOBS.

Source: Facts & Figures 2020, The Mining Association of Canada



Corem



Corem, a world-class organization in mineral processing providing innovative solutions, offers a wide range of services to mining companies worldwide. Its highly qualified staff of more than

145 employees, with a strong health and safety approach, can carry out the most complex projects on base, precious and industrial ores: ore sample preparation and characterization, process mineralogy, complete flowsheet development, bench-to-pilot-scale testing, bankable and feasibility studies as well as the development of iron-ore products and processes, including beneficiation and pelletizing. The center has 10,000 square meters of facilities including two pilot plants with state-of-the-art technologies in mineral processing, hydrometallurgy and pyrometallurgy. Moreover, it includes an accredited analytical services laboratory that performs physical preparation of samples, determination of major and minor elements in various mineral matrices, as well as liquid sample analysis. For more details, visit Corem's website.

Contact:

Gianni Bartolacci

1180 rue de la Minéralogie
Québec, Québec G1N 1X7
Canada

Phone: 1-418-527-8211

Fax: 1-418-527-9188

Email: gianni.bartolacci@corem.qc.ca

www.corem.qc.ca

corem
Innovation in mineral processing



SightPower Inc.

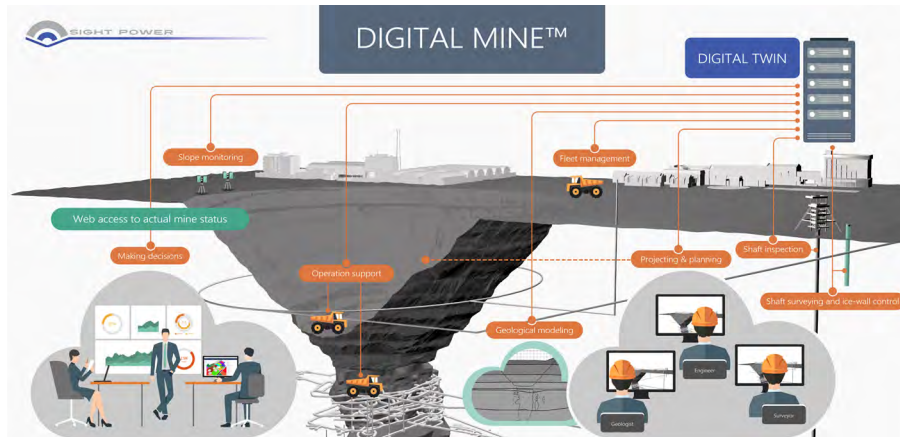

Contact:

Dr. Borys Vorobyov

Chairman Of The Board, SightPower Inc.
109 Solera Circle
Ottawa, Ontario K1T 0C6
Canada

Mobile: 1-613-793-5010

Fax: 1-613-739-1024

Email: borys.vorobyov@sight-power.com

www.sight-power.com



SightPower. SightPower is headquartered in Ottawa, Canada with offices and development centres in Johannesburg, South Africa and Kharkiv, Ukraine. SightPower globally provides digital transformation of a mine site and integration of all mining operations under the trademark **Digital Mine™**. The concept of digital transformation assumes implementation of Digital Twin: dynamic data model of a mine. Digital Twin reflects in a real time any developments and changes which are being happened to a mine. The concept of Digital Mine assumes integration into unified informational space data provided by monitoring, IoT and fleet management systems as well as simulation and modelling systems which are being used. Digital Mine allows the client to make effective business decisions by obtaining uninterrupted access to the distributed newly collected and historical mine spatial

data regardless of its volume and actual location of data servers. **Digital Mine™** concept facilitates to optimize mine-to-mill operations providing operational transparency and effective microplanning. Implementation of **Digital Mine™** concept is based on **Mine Advisor™** platform which includes suite of instruments for geological modeling, mine design and planning, automated surveying with laser-based technologies, and informational support of mineshaft lifecycle, including ice-wall simulation models for mineshafts which are being built, and automated mineshaft inspection systems. SightPower suggests best-in-class visualization engine with practically unlimited capabilities to combine spatial data of any type and any size (geological, CAD, GIS, seismic etc.) which are enhanced by innovative mixed and augmented reality features.



TRACKING THE TRENDS

2021 Closing the trust deficit



TREND 1

Building resilience amid volatility
Scenarios for strategic leaders



TREND 6

Creating an agile supply chain
Overcoming the vulnerabilities exposed by global shocks



TREND 2

M&A in an altered world
Winning back investor trust



TREND 7

The path towards integrated operations
Positioning miners to pivot in the face of change



TREND 3

ESG: Getting serious about decarbonization
From strategy to execution



TREND 8

Advancing the future of work
Redefining leadership and adapting the workplace culture



TREND 4

ESG: Working to overcome the social trust deficit
Linking social investments to sustainable outcomes



TREND 9

On the road to zero harm
Creating the next generation of integrated predictive safety systems



TREND 5

ESG: Corporate governance adding to competitive advantage
Emerging risks mandate greater oversight

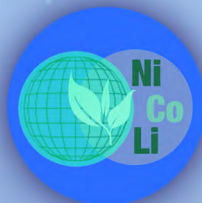

TREND 10

Meeting demand for green and critical minerals
Mining's role in the transition to a clean energy future



Element International Trade Inc.

Element International Trade Inc. established in 2001, headquartered at Montréal, Canada. Element’s other offices/representatives are located in Toronto-Canada, USA, Germany & Turkey. Element International is a leader of semi-bulk transportation in Canada and an important key solution partner in USA & EUROPE for many multinational corporations. Specialized in FIBC (Flexible Intermediate Bulk Container), Our patented design of FIBCs for Fully Automated Filling Systems & Aluminum Liners along with Sea Bulk Container Liners. Serving to Mining, Agriculture, Food and Chemical Industries in 4 continents. Element

International has long term dedicated contract manufacturing facilities in Turkey, India and Bangladesh. Element’s innovative solution for Fully Automated FIBC Packaging systems which is patented FIBC product, providing significant productivity increase for Mining, Chemical and Agriculture Industries. Productivity can increase up to 6 times more at the same production line without changing existing filling system. Add on Robotic system do the job and long-term cost reduction along with short term huge productivity increase provides to our clients unparallel competition advantages in their global markets.

Contact:

Erhan Etiz

620 Boulevard St-Jean, Suite 203
 Montréal, Québec H9R3K2
 Canada
 Phone: 1-877-938-8778
 Email: info@element-trade.com
 www.element-trade.com



EVOLUTIONARY DEVELOPMENT OF INTEGRATED OPERATIONS

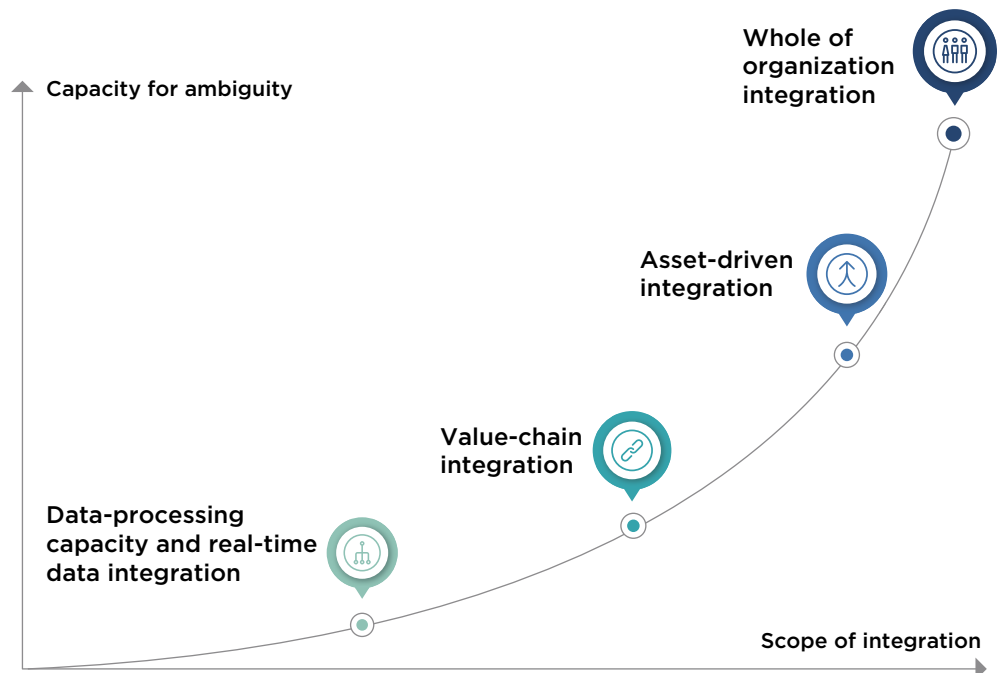

Source: Deloitte Tracking the Trends 2021



Topax Protektive Packaging



At **Topax**, we understand the logistical challenges for ensuring your heavy mining equipment and sensitive components arrive safely on-site. We develop solutions for preserving, packaging and managing the delivery of equipment, so your investment is well-protected against the elements, the rigors of shipping

and is ready to use after transport. Our facility features convenient loading/unloading options at ground level or truck level, as well as crane-assisted lifting. Within the fabrication shop, our experts develop durable, one time and re-usable containers using wood from sustainable forestry sources. We strive to utilize as many environmentally friendly packaging materials as possible. No matter the size or how rushed your shipment is required to arrive, Topax is here to help. Our team will develop a customized comprehensive strategy to ensure your equipment is protected through transport and arrives action-ready, on-site, anywhere in the world. We protect more than just equipment; we protect your reputation.

Contact:

John Ross

Email: john.ross@topax.com

Simon Trillwood

Email: simon.trillwood@topax.com

380 Spinnaker Way
Concord, Ontario L4K 4W1
Canada

Phone: 1-905-669-6464

Fax: 1-905-669-6366

www.topax.com



CANADA IS THE LEADING MINING NATION:

Canada is home to a competitive, sustainable and responsible minerals industry that benefits all Canadians. The country is a global leader in mining-related science, technology, social and environmental practices with a clear and predictable regulatory environment, innovative clean technology solutions, and best management practices. It boasts a skilled and diverse workforce, an attractive investment climate, partnerships with Indigenous Peoples, and strong relations with communities.

Source: Canadian Metals and Minerals Plan (CMMP) 2020



ThreeDify Inc.

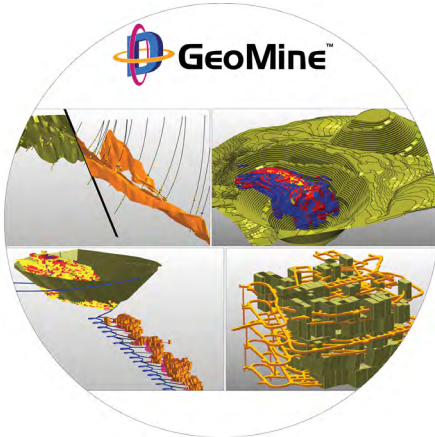

Next generation mining software solutions. Based in Ottawa, Canada, **ThreeDify Inc.** offers innovative mining software solutions to help clients increase resource recovery and reduce mining costs. ThreeDify's competitive advantage lies in their ability to combine advanced modelling and optimization techniques with modern computing technologies in developing next generation mining software.

ThreeDify GeoMine is a well-rounded, integrated package consisting of 12 independently licensed modules. It features an advanced block modeller (GeoModeler), a high performance pit optimizer (FlowPit) and rapid pit designer (QuickPit), a mineable shape optimizer (Stopemizer), a parametric cave optimizer (Cavemizer) and underground design module (uCAD), a unique open pit-to-underground transition optimizer (Optunimizer), a cutoff grade optimizer (OptimCut), a point cloud meshing tool (CloudMesher) for 3D scanners and UAVs, as well as a Life-of-Mine and production scheduler (iScheduler) for both open-pit and underground mines. ThreeDify's solution is scalable, cost-effective and easy-to-use. ThreeDify's license model is very flexible as it offers short-term subscription, perpetual or network licenses.

Contact:

Nancy Liu

Vice President, Operations
2720 Queensview Drive, Suite 1130
Ottawa, Ontario K2B 1A5
Canada
Phone: 1-613-454-5327
www.threedify.com



The Power of Scalability and Flexibility

ESG MANDATES HAVE LONG PLAYED A CRITICAL ROLE IN THE MINING SECTOR, AND NOWHERE IS THIS TRUER THAN IN THE REALM OF COMMUNITY RELATIONS.

Source: Deloitte Tracking the Trends 2021



HEPBURN MINE HOISTS

Engineered in Canada



Installed Worldwide

HEPBURN ENGINEERING OFFERS

New Mine Hoists
complete with controls

- * Double Drum
- * Blair Multi Rope (BMR)
- * Single Drum
- * Friction (Koepe)

Shaft Sinking Winches

Hoist Modernization
Mechanical upgrading
and rebuilding including
advanced braking systems

Electrical Control and automation
systems upgrades

Hepburn Hoist Manager Operating Systems

ISO 9001:2015 Approved

Digital Drives & Controls
DC & AC

Hoist Automation

Ore Pocket Automation and
Weighing Systems

Mechanical & Electrical
Components

Head & Deflector Sheaves

Field Service Inspections
(On all makes of hoists)

Technical Studies & Training

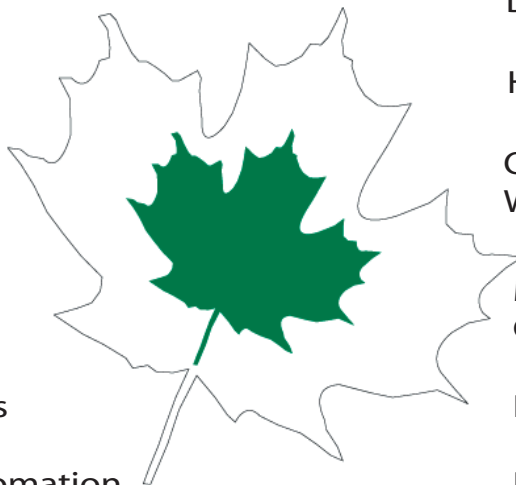

OEM Parts & Service for

HEPBURN, C.I.R., Davy Markham (DM), Westinghouse, F.H.&B. and Ottumwa Hoists.

Hepburn Engineering Inc. designs and supplies the mechanical, hydraulic and electrical components for each hoisting system to produce an efficient integrated package to best meet the customer's requirements.

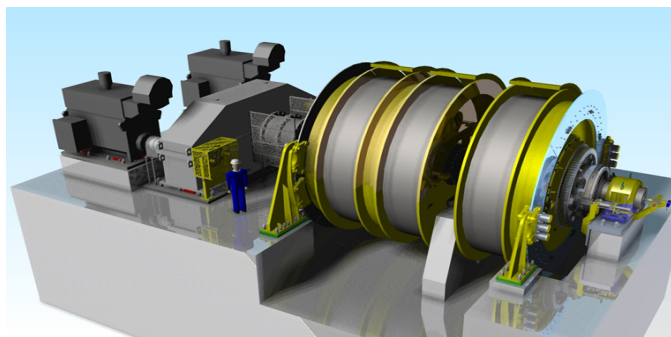

Our design engineers work with the latest 3-D Modelling CAD software and apply their skills to produce advanced hoists with a solid basis in well proven designs.



Three (3) Ergonomic operator's control consoles c/w Hepburn Hoist Manager Operating Software. Each control console operates a separate hoist at an off site location.



HEPBURN ENGINEERING INC.

73 Six Point Road • Toronto • Ontario • Canada • M8Z 2X3

Tel: 416.638.4425 Fax: 416.638.2070

sales@hepeng.com

www.hepeng.com

Boundary Equipment Co. Ltd.

Open-pit mining's single source for critical equipment components and maintenance services.

Services

- Manufacturing
- Repair & Rebuild
- Custom Design & Engineering
- Reverse Engineering

Capabilities

- Cast Components
- Undercarriage
- Gear Manufacturing
- Gearbox Refurbishment
- Hydraulic Cylinders

Areas of Expertise

- Hydraulic Machines
- Rope Shovels
- Drills
- Apron Feeder Pans
- Mineral Processing
- Draglines

Featured Innovations

- CAT 7495 Undercarriage / Lowerworks
- Point Sheave
- Padlocks
- Posikeeper™
- Track Shoes

Boundary Equipment specializes in Aftermarket Mining Replacement Parts. In collaboration with our affiliates ISS Mine Safety, United Gear, and Bridge Machine, we offer a single source for design, manufacturing, replace and repair, or custom solutions for critical mining equipment parts and components. Our ISO 9001:2015 certified quality management system and comprehensive service approach help ensure our customers expectations are met or exceeded every time. For projects done right - the first time, contact Boundary.

Contact:

Alex Tutschek

President
10740 - 181 Street NW
Edmonton, Alberta T5S 1K8
Canada
Phone: 1-780-666-7517
Fax: 1-780-484-1299
Email: boundary@boundaryequipment.com
www.boundaryequipment.com

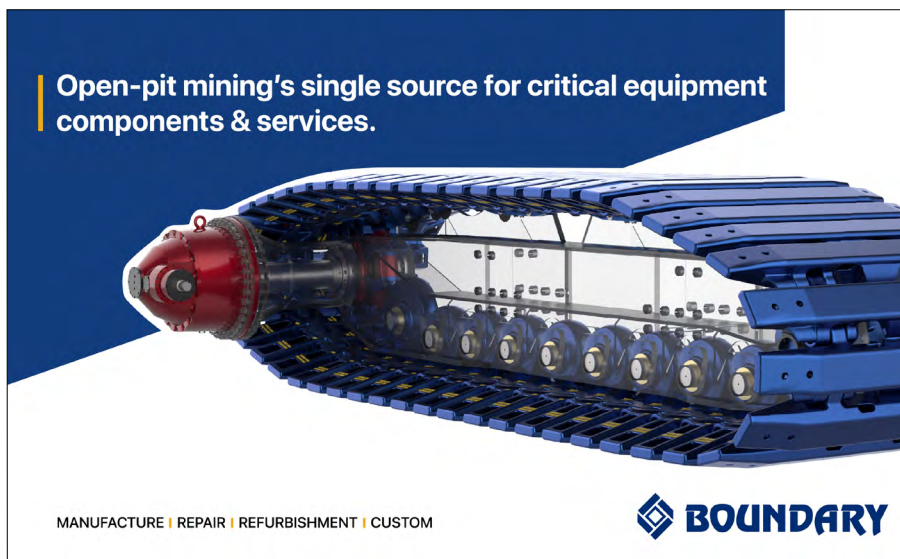

Valley Blades Limited

Valley Blades Limited, ISO 9001:2015 certified, manufactures replacement wearing edges for earth and snow removal equipment, including bulldozers, road graders, loaders, scrapers, excavators and snowplows. These wearing edges are manufactured using computer-assisted technology to rigid specifications that meet or exceed those set by the original equipment manufacturer. Since it began in the early 1960s, Valley Blades Limited has grown into a world supplier of

replacement wearing edges and has built a strong dealer network that supplies competitively priced, quality products and reliable service backed by an extensive inventory. Valley Blades Limited manufactures replacement wearing edges for Caterpillar, Komatsu, Deere, Case, Terex, Volvo and more, and has manufacturing facilities located in Waterloo, Ontario and Edmonton, Alberta, to serve the mining industry nationwide and customers around the world.

Contact:

Bruno Montesano Jr.
 Sales Manager
 Email: bruno@valleyblades.com
 435 Phillip Street
 Waterloo, Ontario N2L 3X2
 Canada
 Phone: 1-519-885-5500
 Toll Free: 1-800-461-1824
 Fax: 1-519-746-2780
 Email: sales@valleyblades.com
www.valleyblades.com



DIGITAL ROAD MAP POWERED BY HUMAN-MACHINE COLLABORATION

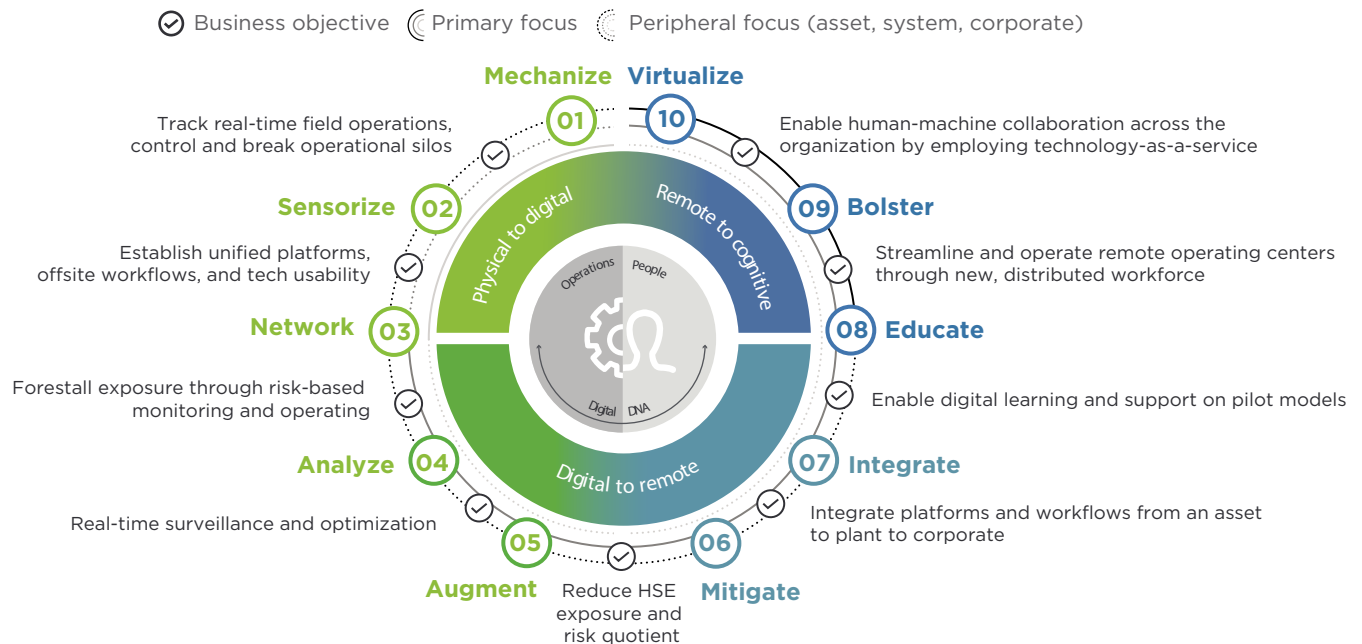

Source: Deloitte Tracking the Trends 2021



Cole International Inc.

Cole International Inc. is one of Canada's largest privately owned international freight forwarders and customs brokers, also providing a variety of customs and compliance consulting services. With offices in all major Canadian cities and located at strategic points throughout the U.S. (including all major Canada/U.S. border crossings), Cole has been meeting and exceeding requirements of the resource-based industrial sector for more than half a century. Cole recognizes the demands of delivering critical components to

remote locations while navigating a web of complex foreign customs regulations. Its professionals have the technical knowledge and experience to ensure your exports are handled smoothly, efficiently and accurately every time. As a successful Canadian company competing in the global marketplace, Cole understands many of the obstacles faced by MSTA CANADA members and is uniquely equipped to provide the right specialized logistics solutions to help your business compete and achieve your goals.

Contact:

Derrick Sones

Director, Freight
1111 - 49th Avenue NE
Calgary, Alberta T2E 8V2
Canada
Phone: 1-403-262-2771
Toll Free: 1-800-268-2965
Fax: 1-403-262-7301
Email: derrick.sones@coleintl.com
www.coleintl.com



CANADIAN MINING INDUSTRY

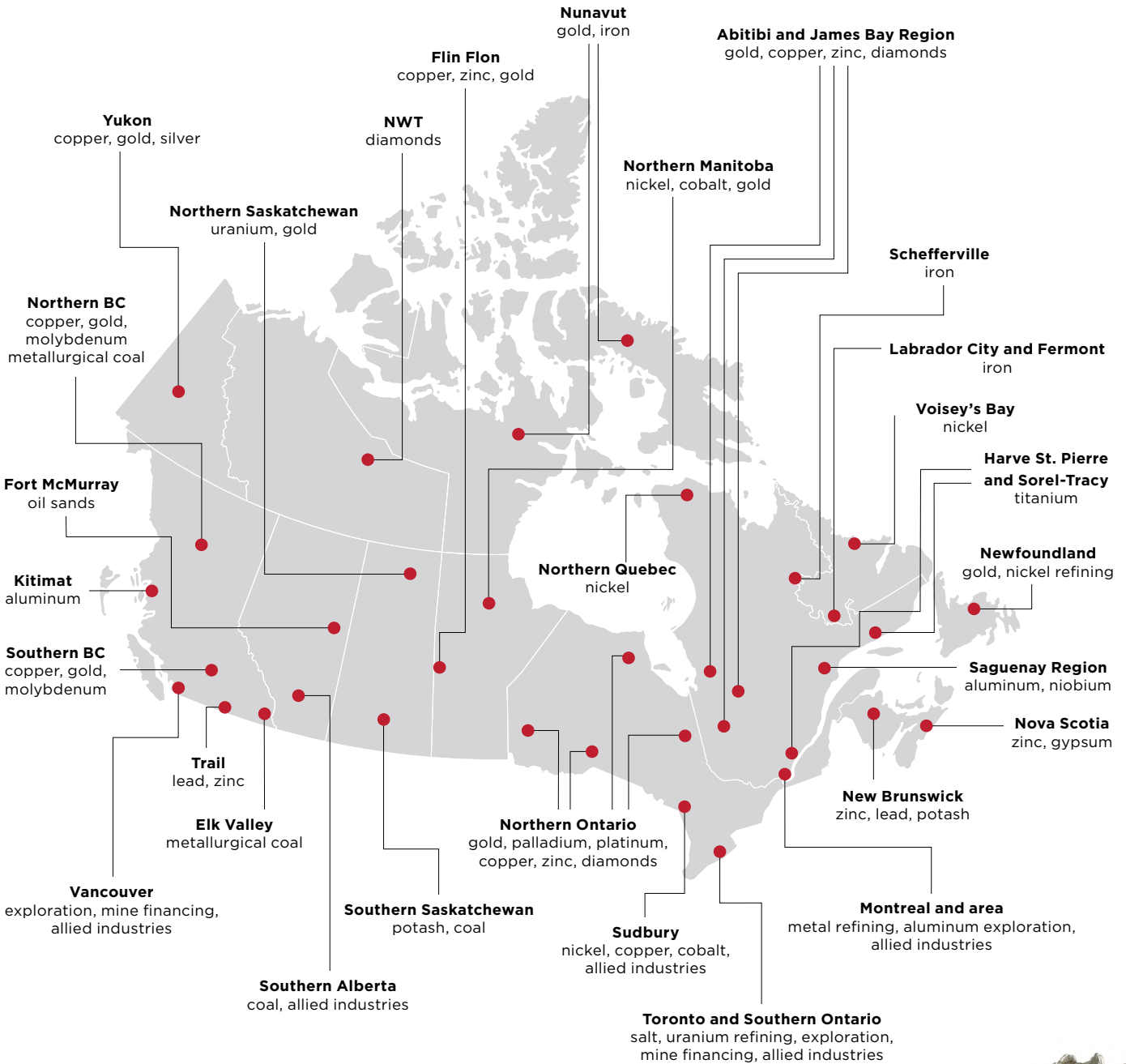
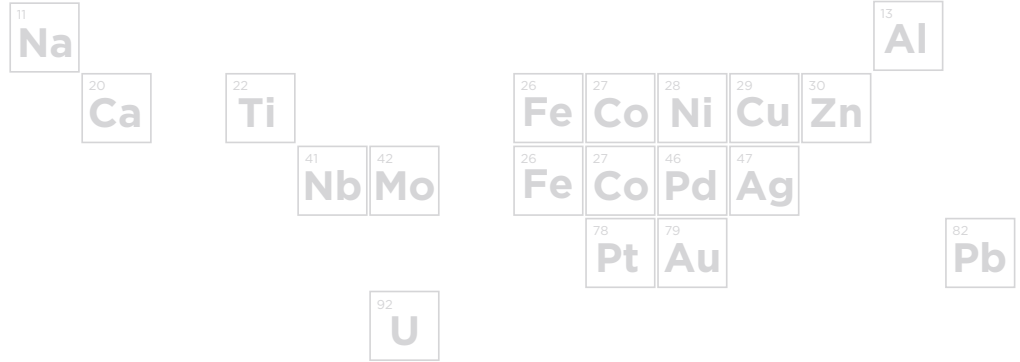

Source: The Mining Association of Canada



BPT Components & Parts Inc.

BPT Components & Parts Inc. is a leader in the Clark Powertrain market. With its state-of-the-art dyno-test machine to ensure its products meet or exceed OEM standards, BPT inventories more than \$5 million in Clark/Dana Powertrain components and replacement parts for the mining, logging and construction industries. In addition, BPT is a

Carraro warehouse distributor and Funk authorized dealer. Now BPT can provide you with more lines to help keep your machines running with OEM parts at competitive prices. Turn to BPT to keep your equipment up and running with the highest quality parts and components at exceptional savings for you, the customer.

Contact:

Tim Edwards
2335 Maley Drive
Sudbury, Ontario P3A 4R7
Canada
Phone: 1-705-524-8400
Fax: 1-705-524-8422
Email: tim@bpt.on.ca
www.bpt.on.ca



For all your Clark/Dana Powertrain
Your Transmission Centre for Clark/ Dana - Carraro - Funk - JCB

Seal kits - Bearing kits - Hard parts - Disc kits - Charge pumps and more



CARRARO

Canada's official spare parts distributor

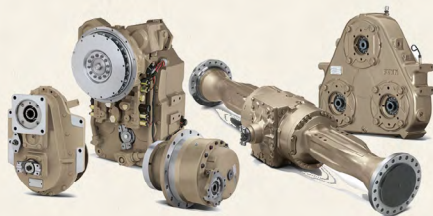

FUNK
DRIVETRAIN
COMPONENTS

www.bpt.on.ca

Sudbury - Toronto Canada
705-524-8400 email: sales@bpt.on.ca



L&M Powertrain Parts

Since 1959, **L&M Powertrain Parts** has set the standard for performance and quality in powertrain parts and components for off-road vehicles and has become one of the leading suppliers to the mining industry worldwide. L&M specializes in

supplying transmission, torque converter, differential and planetary axle parts for dealers, distributors and re-builders servicing machines such as Atlas Copco, Dux, Eimco, Jarvis-Clark, GHH, JCI, MTI, Sandvik, Tamrock, Toro, Volvo and Wagner.

Contact:

Tony Mainelli

201 Snidercroft Road
Concord, Ontario L4K 2J9
Canada

Phone: 1-905-669-2292

Toll Free: 1-800-387-3765

Fax: 1-905-669-6319

Email: parts@landmparts.com

www.lmpowertrainparts.com



SPICER®

Off-Highway Systems

MacLean



MacLean Engineering specializes in underground mobile equipment solutions based on hard rock mining experience, multi discipline engineering capability, unit-of one manufacturing expertise, and worldwide customer service and support. The company's product suite includes platform and utility bolters, shotcrete sprayers, and transmixers in the ground support category; remote operated blockholer drills, mobile rock breakers, and water cannons in

the ore flow/secondary reduction category and, Mine Mate™ scissor lifts, boom lifts, boom trucks, ANFO/emulsion chargers, personnel carriers, fuel/lube trucks, cassette trucks, fan and pipe handlers, and service drills in the utility vehicles and attachments category. MacLean has been innovating for hard rock mining mobile equipment safety and productivity for almost 50 years, supporting customers worldwide with branches across Canada as well as in United States, Mexico, Peru, South Africa and Australia. The latest chapter in the MacLean innovation story is the introduction of full-fleet electrification, integrating best-in-class battery and electric drive technology to deliver a safe, proven, and data-rich option for diesel-free operations in the underground environment. For more information, please visit www.macleaneengineering.com

Contact:

Stuart Lister

Vice President of Marketing
& Communications

Email: slister@macleaneengineering.com

Phone: 1-705-241-3247

Tony Caron

Vice President, Latin America
& Québec

Email: tcaron@macleaneengineering.com

Phone: 1-705-690-1325



Trojan Tire Inc.



Trojan Tire Inc. is the manufacturer of patented Soft Core® – Trojan Air-Cell® Rubber Tire Fill. Soft Core ensures no lost downtime due to flat tires

for huge productivity gains. The Trojan Air-Cells flex with a tire’s load to absorb shock and provide an air-like ride for machinery and operator. Soft Core is reusable, increases load capacity, eliminates air = no explosive force, provides best traction, is safe to handle and is best for the environment. Soft Core can increase tire life up to 25 percent. Trojan Soft Core is up to 10 times stronger than weak polyurethane to carry heavy loads and is resistant to breakdown – for best productivity. Soft Core is used in underground mines on production and support equipment.

Contact:

Ryan Powers

Sales Manager
 960 Gateway Drive
 Burlington, Ontario L7L 5K7
 Canada
 Phone: 1-905-633-6886
 Email: ryan.powers@trojantire.com
 www.trojantire.com



TROJAN TIRE

CANADIAN MINES IN 2019:

1,001

Total mining establishments:

70

Metals:

931

Non-metals:

PROVINCES WITH THE MOST METAL MINES

24 QUEBEC

18 ONTARIO

9 BRITISH COLUMBIA

MAIN TYPES OF NON-METAL MINES

571 Sand and gravel

265 Stone

50 Peat

Source: Facts & Figures 2020, The Mining Association of Canada





sudbury

we innovate, educate, supply,
research, and service the mining world.

global
mining
hub

investsudbury.ca

@ResourcefulCity

PLEASE SEE OUR LISTING ON PAGE 20

Accutron Instruments Inc.

Accutron Instruments has been leading the underground mining community with ultrasonic time-of-flight ventilation monitoring since 1993, and continues to advance their technologies for all ventilation-dependent industries. Accutron's ultrasonic technology remains to be the most effective and reliable solution for continuous monitoring of air movement in mines, tunnels and other industrial venues. Accutron continues to strengthen their technology with it's latest airflow monitoring solution, the Accutron PRO Series. Their improved connectivity and local control allows users to create their Mine Air Quality Stations and Optimization around the Accutron

Pro Controller, combining it with the improved FlowTRAX PRO (airflow), ClimaTRAX PRO (DB, WBGT, RH, P), Gas, Dust and DPM. The Accutron PRO Web Interface opens up the live data dashboard with a complete suite for device configuration and management. This Proudly Canadian manufacturer is also partnered with other global leaders in the industry of real time particulate monitoring of respirable dust and diesel particulate matter (DPM) to bring the best technologies to our clients to better understand their environment underground. For more information; contact to schedule a discussion and live demonstration from their Wind Tunnel Test Chamber.

Contact:

Chad Methe, Mechanical EIT (B.Eng)
Sales, Service Manager
Business Development
Phone: 1-705-682-0814, ext. 1104
Email: chad@accutroninstruments.com
www.accutroninstruments.com



MANY COMPANIES ARE ADOPTING A RANGE OF LEADING PRACTICES AS THE MOVE FROM DECARBONIZATION COMMITMENTS TO ACTION, BALANCING SHORT-TERM ECONOMIC FACTORS WITH LONG-TERM ENVIRONMENTAL IMPACT.

Source: Deloitte Tracking the Trends 2021



G+ Industrial Plastics



Since 1995, **G+ Plastics** has broken new grounds by manufacturing exclusive, high-performance plastic products for the mining industry. Lightweight, heavy-duty,

long-lasting, and corrosion-resistant, plastics are suitable for an array of health and safety products designed to better protect mining workers. Thanks to its expertise in industrial plastics, G+ Plastics is revolutionizing mine ventilation with the G+ SPEED AIR DUCT. Flexible yet robust, this semi-rigid vent tubing with unparalleled airtightness conveys air efficiently over great distances while minimizing vent line energy consumption. Choosing the G+ SPEED AIR DUCT also means having access to the company expertise. G+ Plastics offer technical support to optimize the duct performances during the design stages and provide on-site training to ease the installation process. Finally, G+ Plastics visit client sites to conduct vent line performance surveys and further assist in its clients needs.

Contact:

Pierre Trudel

Vice President

180 rue d'Evain

Rouyn-Noranda, Québec JOZ 1Y0

Canada

Phone: 1-819-768-8888

Fax: 1-819-768-8777

Email: info@plasticminer.com

www.plasticminer.com



SEVERAL MINING ORGANIZATIONS HAVE ACTED SWIFTLY TO MITIGATE INBOUND SUPPLY RISKS. TWO MAJOR AREAS INCLUDE THE MOVE TO CREATE ALTERNATE SUPPLY LINES AND REEVALUATING INVENTORY STRATEGIES.

Source: Deloitte Tracking the Trends 2021



MINE



VENTILATION



PERFORMANCE



plasticminer.com

PLEASE SEE OUR LISTING ON PAGE 70

McCue Engineering Contractors

McCue Engineering Contractors is an award-winning Canadian engineering and construction company. We supply leading edge, pre-packaged and custom water and wastewater treatment systems, and have a proven track record of delivery and customer service. We pride ourselves on being nimble, entrepreneurial and responsive. No water problem is too complex. McCue Engineering Contractors es una compañía Canadiense

ganadora de multiples premios que brinda servicios de ingeniería y construcción. Proveemos sistemas de tratamiento de aguas con tecnología de vanguardia, hechos a medida y preensamblados, con un historial comprobado de servicio al cliente. Nuestro orgullo es ser emprendedores con una gran capacidad de respuesta. Ningún problema de aguas es demasiado complejo. Hablamos Español, no dudes en enviarnos tus consultas.

Contact:

McCue Engineering Contractors
8291 - 92nd Street, Unit 203
Delta, British Columbia V4G 0A4
Canada
Phone: 1-604-940-2828
Email: info@mccuecontracting.com
www.mccuecontracting.com



BROWNFIELDS TO GOLD MINES



SERVING OUR MEMBERS FOR 40 YEARS

Over the course of our four decades as an association representing the mining supply and services sector, MSTA CANADA is proud to have provided support to our members through a variety of services, including our international trade programs.



30

Countries Visited



>6,000

Companies Served



>225

International Events Hosted



4,000,000

Visitors to Canada Pavilions

→ [Learn more about what we do.](#)



BTI'S ROUGH AND TOUGH PRODUCTS ARE FINE-TUNED TO INDIVIDUAL CUSTOMER DEMANDS

The company's durable products are built to tackle Job One in mining: breaking rock.

With more than 60 years of experience manufacturing and distributing mining and quarrying equipment across Canada and around the world, there's good reason Breaker Technology (BTI) is known as "the rock-breaking expert."

Now an Astec Industries company, BTI started life in Thornbury, Ontario (where it is still located) back in 1957. The 6,000 square foot shop produced custom-machined products for a range of local industries before homing in on its core competency – mining and rock breaking equipment.

Terry McKague, Director of Canadian and International Sales, says the company's sweet spot is the tough end of the bell curve, where there are few products that measure up. "The customers who want our solutions are those that have very demanding applications." Among them are companies like Chile's Codelco, the largest copper mining company in the world, which looks to BTI's trademark tough and reliable products.

Manufacturing this type of equipment isn't a one-size-fits-all enterprise. Systems are custom fitted to the mine or quarry application to ensure maximum endurance. That requires a high degree of knowledge and customer service. "Each mine is different. We listen to the customer's needs, and that often results in custom-manufactured machines," says Terry. "The service that goes with it is important."



While that used to mean hopping on a plane to find out about the client's needs or problems, in today's post-pandemic world it's more likely to mean hopping on a Teams call, but the net result is the same: "Customers just want to know there's a factory that cares about them," says Terry.

Having good local partners in their overseas locations, which include Peru, Chile and Africa, is also essential. Some of these relationships were formed after joining CAMESE (now MSTA CANADA) back in its first days. "In the early 80s, we travelled extensively with [first CAMESE managing director] John Needham, and were part of the CAMESE International Trade Program. We still have some of the original partners we met through those networking opportunities."

Membership in the association also helped the company make inroads into the Chinese market in the early 90s. "It was unusual at that time for a company to fly to China to sell. MSTA CANADA helped us get into places we normally couldn't."

Another key ingredient in the company's success is continual innovation, such as BTI's award-winning tele-remote equipment, which helps keep miners above ground where it's safer. He says companies with integrity and vision "will always have resilience in the industry. Any company that embraces innovation will have a place. You have to keep going to the next step."



Learn more at www.rockbreaker.com



CANUN'S WINNING COMBO

This family-run business combines friendly service and product expertise with a laser-sharp focus on quality assurance.

CANUN International specializes in manufacturing and servicing pneumatic rock drills and replacement parts.

“We’ve been making the same product for 40 years – ever since we opened our doors in 1981,” says Peter Cirelli, President. “We’re considered the experts because we’ve been doing it so long that we can solve any problem when someone calls.”

And when they call, CANUN answers – with a live human voice, a rare commodity these days. “There are ten of us in the Sudbury office, and we’ll pick up each other’s phone if the person isn’t there. Customers say they appreciate the friendly service and quick answers we provide.”

CANUN fills a niche market with products manufactured within Canada. Manufacturing is contracted out to a shop in Toronto that has the necessary machinery, though CANUN retains ownership of the tooling and the technical knowledge. Having “the appropriate expertise in the proper place” is key, says Peter. The Sudbury head office is solely responsible for the assembly and testing as well as the quality control of each individual part, which undergoes a thorough inspection before either assembly or sale.

“A rock drill has a life span of 20 years,” explains Peter. “Many parts will need changing during that time, so they have to fit properly. Threads, for example, have to be accurate and clean, with no burrs.”



Repairs are also important to the business model, a reflection of industry changes. “Ten years ago, mines had their own mechanics. Now they outsource all the servicing,” says Peter. “We have several contracts with large operations. Mining contractors will also bring their drills in before starting a contract so they’re in good condition.”

The company website uses the tagline “Drilling, it’s in our veins,” a reflection not only of their commitment to the industry, but also the fact that it’s a family-run business. Peter’s own father worked in mines repairing drills, and Peter’s wife Janice worked for the company for 25 years. Peter’s son, Douglas, is the Production Supervisor and has worked at the company for 10 years, as has his wife, Julie. After graduating from the mining engineer and technologist program at Cambrian College, Doug worked at Vale before starting work at CANUN, which provided valuable first-hand knowledge.

Their plan is for Doug to take over the business when Peter retires. “I’d like to see it grow in some areas, such as introducing new product lines,” says Doug. “But the company values will always remain the same: quality, customer service and a good working environment for our employees. Those will always be important to us.”



260B

CANUN
Rock Drills

5
Continents
Served

0
Lost Time
Accident Hours

Learn more at www.canun.com



FOR NEARLY 100 YEARS, RELATIONSHIPS HAVE SHAPED THE HEATH & SHERWOOD STORY

From its founding, to its flagship product, to international expansion, strong connections are behind the success of this venerable company.

In the 1930s Clarence Heath and Ellsworth Sherwood combined their expertise in geology, machinery and drilling to open a diamond drill machine and repair shop. Since those early days, the company has grown and evolved significantly, but partnerships — often rooted in friendships — have been a central theme.

In the late 50s, the company was split into two divisions, allowing each to focus on a core expertise of either drilling or manufacturing. Heath & Sherwood Limited assumed manufacturing of the diamond drill equipment and supplies. In 1964, Heath & Sherwood (1964) Ltd. (H&S64) was formed when Ed Marinigh, Ed Mangan and Frank Aimone — who would later become one of the original founders of OMESE (now MSTA CANADA) — joined forces to purchase the business. Then in 1997, yet another partnership came to the forefront, when employees Peter Marinigh and Michael Marinigh (Ed's sons), along with Phillip Cancilla, teamed up to purchase the company.

Another important relationship was the company's partnership with Noranda Research. "We manufactured equipment for new products and processes they were developing," says Phil Cancilla, Sales & Marketing Manager and Partner. "And that relationship, in turn, was a result of Frank Aimone's friendship with an engineering school classmate."

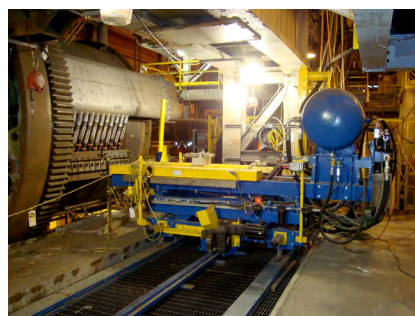
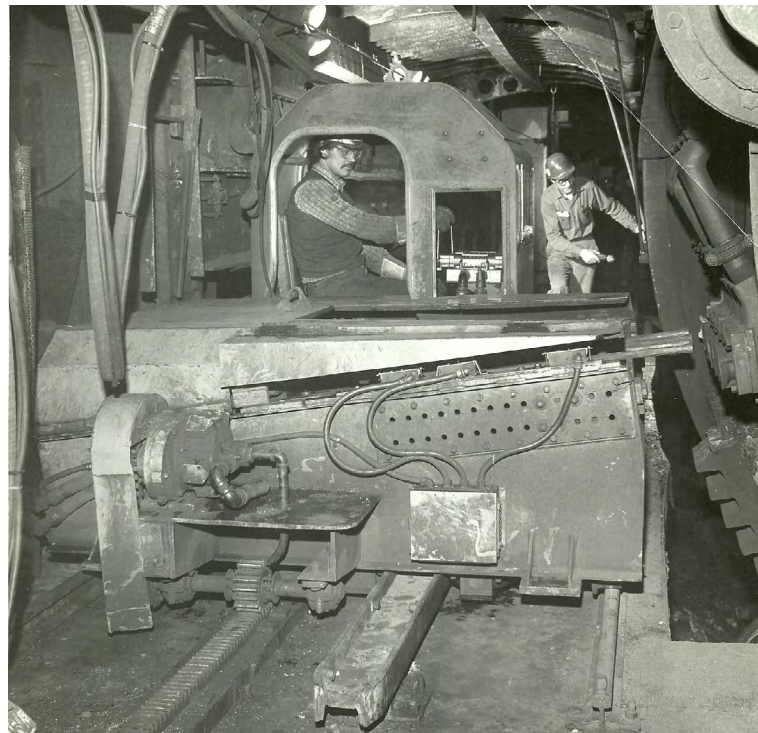

“I was taught there are three rules in sales: relationships, relationships, and relationships. That’s what Heath & Sherwood is about, and that’s also what MSTA CANADA is about. Its root purpose is to put people together — to grow companies.”

One outcome of that connection was the game-changing Gaspé Puncher. Before its introduction in 1968, a two-person team would work alongside the smelting vessel in the worst of conditions to manually punch out the clogged tuyères (openings) with a rod and sledgehammer. It was a dangerous but essential role that could result in serious injuries or even death. Now ubiquitous, the Gaspé Puncher increased mining safety, and its continual improvements have produced five generations of the model plus multiple spinoffs and accessories.

Over the years, the company has become particularly well known for products that aid in managing the tuyère line and for an extensive range of reliable metallurgical sampling devices.

Exporting, an area where relationships are certainly key, has played an important role in their success. In the early 90s they licensed Consep Pty Ltd of Australia to manufacture and sell H&S64 products, a partnership that enabled them to penetrate the Pacific Rim. That relationship has developed for more than 20 years and moved to a new vision in 2018 to combine their know-how and expertise, providing better worldwide exposure for both companies.

Notably, Peter Marinigh (H&S64) and Grant Steward (Consep) met in the early 1990s at a mining trade show in Indonesia, where H&S64 was one of MSTA CANADA’s trade booth delegates. The company’s long-standing connection to MSTA CANADA is yet another relationship that has been important to their growth.

“MSTA is about exporting and, like us, it recognizes the importance of connections,” says Phil. “Many companies aren’t sure how to start exporting. It can take a long time if you try to do it alone.”



Learn more on **page 49**



MOTION METRICS BRINGS PRODUCTIVITY TO MINES WORLDWIDE

The company's 3D imaging and AI technologies make mining safe, smart and sustainable

Armed with some of the most advanced and rugged technology on the market, Motion Metrics is a trusted partner in mining innovation. The company is an industry leader in missing tooth detection and particle size analysis, with a growing suite of solutions aimed at improving mine safety, productivity and efficiency. Its products are designed, manufactured and tested to military standards at its Vancouver, BC headquarters.

Motion Metrics began as a sole proprietorship and grew over several years into a multinational company with offices on five continents. Its products have now been installed at more than 70 large mines operating in the world's toughest environments. "Many mining companies will only use shovels and equipment that have our monitoring systems installed," says Motion Metrics CEO and Founder, Shahram Tafazoli.

Motion Metrics owes much of its position as a market leader to an early investment in AI. In 2014, the company hired a University of British Columbia (UBC) electrical engineering graduate to develop LoaderMetrics, a monitoring system that uses thermal imaging and deep learning algorithms to detect missing loader teeth before they can travel downstream and obstruct the crusher.

"I knew we were onto something important, and that we needed to put more into this," says Shahram. "We needed an entire artificial intelligence (AI) department."



Today, Motion Metrics incorporates AI in all its products. These systems use technologies like rugged thermal imaging, 2D or 3D cameras, and deep learning algorithms trained on data from around the world to capture and analyze data more accurately than humans can.

In this era of escalating climate crisis and increased pressure on natural resources, Motion Metrics is also using its technologies to reduce the impact of mining on our planet. Motion Metrics recently received \$5.6 million in funding from Sustainable Development Technology Canada (SDTC) for a multi-year, multi-party project that will use its machine vision and deep learning technologies to dramatically improve energy efficiency at mines worldwide.

“Comminution, the process of reducing particle size so that valuable minerals can be liberated from the ore, accounts for about half the overall power consumption at an average mine site,” says Shahram. “By using advanced digital imaging and Artificial Intelligence of Things (AIoT) sensors to measure particle size and mineral composition, we can reduce energy consumption and eliminate waste at various stages in the size reduction process. Although it is still early days, the Motion Metrics team is very excited to join the fight against climate change.”

As part of its commitment to make a positive contribution to the regions where it does business, Motion Metrics recently purchased 100 half-ounce Rhino Gold Bars from B2Gold and distributed them to employees.

“I learned about the poaching crisis in Namibia during an MSTA trade mission to the region in early 2020,” says Shahram. “I’m grateful for the opportunity to play a small role in helping to protect this species and support the communities that depend on them.”



100+
employees

70+
mines

6
continents

Learn more on **page 28**

MOTION METRICS



NCA'S CUSTOM SOLUTIONS SERVE DRILLING AND MINING OPERATIONS ON EVERY CONTINENT

The relationship-based approach of this family-run business has taken it to every part of the globe to meet the specific needs of their customers.

About 50 years ago, when engineer David Keddie was in the early days of his career, he observed that there were opportunities in mining in Northern Ontario. So he began providing drill bits and consumables, eventually building a team of dedicated professionals to design and manufacture specialty compressors to meet that need. Little did he know what an important move that would be.

Today, National Compressed Air (NCA) designs and manufactures custom engineered compressor systems, primarily for drilling applications (both land and offshore) in the oil and gas and mining sectors, and is the leading innovator in booster compressors for underground drilling and compressors for remote locations. The company's products operate in the most extreme working conditions and provide the high pressures demanded by today's more powerful drilling equipment, which can require as much as 5,000 psi.

NCA's big break came when it sold its first booster compressor to a mine in Chile. "When contacts at Inco [now Vale] heard it was being sold overseas, they figured it must be worth looking at," recalls David, who is now the Board Chair of the company. That led to long-term collaboration with Inco Mines Research, a relationship originally facilitated through NCA's membership in CAMESE (now MSTA Canada).



In addition to developing products with increasing power, NCA has also focused on developing products that offer portability, such as modular compression systems that can be moved by helicopter to remote work sites. That plunged them into the world of oil and gas seismic exploration, which in turn led to applications in oil and gas well drilling and pipeline services, a sector that forms a large part of their business today.



“We work with everyone from small ‘mom and pop’ drilling contractors to large multinational operations like Halliburton and Boart Longyear,” says David’s son, Derek Keddie, President of NCA. But no matter how small or how large the client, he says, the business is based on relationships. And every relationship begins the same way: by listening to the customer.



“We’re not selling a commodity,” says Derek. “We sit down with each client to figure out what their needs are.”

The company now operates four manufacturing locations in Canada, to serve clients across the country and around the world — with projects on every continent, including Antarctica. “The majority of our work is international, either with North American clients working abroad or through export sales,” says Derek.



Along with mining and oil and gas, the company has diversified into a wide range of sectors including industrial, construction, utilities, petrochemical and transportation, and new applications including gas generation and gas compression systems.

Whatever the size or sector of the client, NCA’s focus remains on providing innovative, application-specific solutions customized to the specific needs of that company.

Learn more at www.nationalcompressedair.com



NORTHERN LIGHT TECHNOLOGIES SHINES THROUGH THE DARKNESS

Whether lighting up a job site, establishing underground connectivity or manufacturing PPE, safety always comes first for this company.

Many companies have had to pivot during the pandemic, and Northern Light Technologies (NLT) is a shining example of how to do it well. Known for manufacturing their best-in-breed mining cap lights, the company witnessed early on the shortage of surgical and N95 masks and jumped into action. By the end of Q1 2020 they were manufacturing ASTM Level 2 surgical masks for Canadian and international distribution.

The company is also now making a new Pleats+ N95 equivalent line with the CAN95 designation, scheduled to deliver at the end of Q1 2021. These duckbill-shaped masks have extra pleats for greater comfort and easier breathing and are expected to be popular amongst healthcare workers.

Heidi Levitt, co-CEO of Levitt-Safety and Global President of NLT from 2007 to 2019, explains: “Getting certification from the National Institute for Occupational Safety and Health (NIOSH) to use the N95 designation is a lengthy process. The Can95 standard is a new designation that mirrors NIOSH requirements, allowing high-quality respirators to get into the market more quickly.”



Switching from manufacturing mining equipment to healthcare equipment isn't as big a leap as it might seem. NLT is a wholly owned subsidiary of Levitt-Safety, a leading supplier of safety products that was founded in 1935 by Heidi's father. Seeing a need for better mining lamps, Levitt-Safety started NLT to bring their new technology, the "Orange Cap Lamp," to market. Today the company has offices in Canada, Australia, Chile and Germany, and distribution partners in most of the important mining capitals around the world.

NLT is best known for their award-winning Polaris, the first MSHA-approved all-in-one cap lamp. It eliminates the need for a cord, which is a dangerous liability in tight underground spaces.

While NLT products are designed and supported in Canada, "our international distributors understand them as well as we do," says Heidi. "One of the key differentiators of the cap lamp is that it's not disposable. Properly trained distributors and end users can replace parts and batteries themselves, thereby extending the life of the caplamp. That's important in our sustainability-focused world, but it's also critical for international companies, where the need to be economical is especially important."

NLT also makes network products for coal and hard rock mining. These expandable, easy-to-maintain modular systems improve safety by aiding communication, tracking employees, managing ventilation and providing VOIP and other functions. Other innovations in development include safer batteries, longer-lasting LEDs and proximity detection devices to prevent underground collisions.

"Canadian technology is making mines and tunnels safer, more productive and more state-of-the-art," says Heidi. "Innovations like those from Northern Light Technologies provide both the safety that customers want and the efficiency they need to drive the all-important bottom-line savings."

Learn more at www.nltinc.com



THE MANY FACES OF PHOENIX GEOPHYSICS

Like its namesake bird, this company has repeatedly reinvented itself, but always with an eye on producing innovative equipment to aid mining and other resource exploration and research.

When Phoenix Geophysics was formed in 1975, the company had already been through a previous incarnation – the company known as McPhar.

In an unheated garage in Toronto back in 1947, a group of young physicists started a company to develop test equipment for electromagnetic (EM) surveys, in partnership with INCO (now Vale). EM was a fairly young technology at that time.

McPhar’s many later innovations included airborne EM systems, both passive (AFMAG) and active source.

McPhar became so successful that it was purchased in 1970 by Canadian Industries Limited (CIL), whose products included mining explosives. But just five years later, CIL sold McPhar to another company. Since they had not been offered the opportunity to purchase it themselves, a group of six employees formed their own company. And so, in 1975, Phoenix (and its famous logo) were born.

The fledgling Phoenix vowed to adhere to McPhar’s original values of continuous improvement and innovation.

Leo Fox, now President, joined the company in 1982. “Phoenix has developed eight generations of geophysical equipment in four decades. We’ve been considered the world leader in MT (magnetotelluric) technology since 1980,” he says. “Our equipment is now used in more than 80 countries.”



EMPower Software



Ultra-wideband MT Systems



MT and AMT (audio-frequency MT) technology is a cost-effective way to identify metallic mineral deposits deep underground that may be undetectable with other EM methods. In 1992, for example, Phoenix MT equipment detected what was then the deepest metallic deposit ever confirmed by MT — the Trillabelle nickel deposit in Sudbury, Ontario, situated 1,750 metres below the earth's surface.

MT is also used to search for kimberlites, porphyry copper and other base and precious metal deposits. Ultra-sensitive Phoenix Phase IP was instrumental in detecting very subtle IP anomalies from the narrow gold bearing veins of the Hemlo deposit (northern Ontario) in the 1980s.

Leo says their latest generation of ultra-wideband (UMT) equipment is even better engineered and more thoroughly tested than any previous generation. In part, he says, that's a natural evolution of the business. For example, in the old days geophysicists would pick up some programming courses at university and apply that in their work. But now software is highly engineered by software specialists, and Phoenix's structure reflects this shift. "In 2010 we had no professional software developers; now we have ten software professionals who ensure the systems are accurate and bug-free."

A key development in the latest generations of the technology (since the late 1990s) is the incorporation of GPS to provide precision timing for MT and other techniques. This has reduced costs considerably, and led to an increased uptake of the equipment, from hundreds to thousands of units.

"It's an adventurous business, with moments of high drama and great risk, both physical and financial," says Leo. "In the old days, sometimes just meeting payroll was a thrill, but we're on much firmer ground now."

Learn more at www.phoenix-geophysics.com



Photo courtesy of Dr. Kerry Key, Columbia University.



HOW SHAW ALMEX EVOLVED FROM SMALL-TOWN STARTUP TO INTERNATIONAL SUCCESS

The story of Almex Group's (a.k.a. Shaw Almex Industries) rise to global success from humble small-town roots is based on targeted expansion and innovation around the company's core expertise: bulk material handling.

Shaw Almex Industries began its steady climb to international success from a small shop in Parry Sound, Ontario. When E.J. Alm invented the pressure bag system in 1962, his patented technology revolutionized conveyor belt press design. The pressure bag quickly became standard technology across many different industries, including mining, where getting material from point A to point B is mission critical.

Ever since, the company's story has been one of growth and innovation.

In the late 90s, Shaw Almex expanded, through a series of acquisitions, into consumables such as the glues and rubbers that join the belt ends, cover pulleys and repair conveyor belts. Then, during the global financial crisis, they added four new locations and began investing in technology.

In 2017, Almex Group acquired EMSYS GmbH, a technologically advanced belt asset management system that detects rips using SmartWires and RFID sensors instead of outdated analogue antennas. The monitoring system can be operated on site or remotely so issues can be identified, diagnosed and fixed from anywhere in the world.

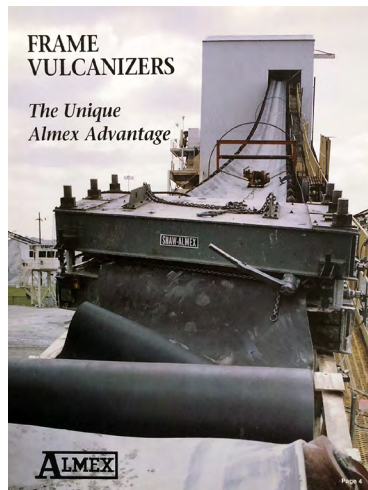

400
employees

123
countries

18
locations



**“We don’t cut back during hard times.
We innovate and spend.”**

— Tim Shaw, CEO, Shaw Almex Industries

EMSYS Product Solutions are used by the world’s largest mining companies and projects. “There are no competitors who can do what it does, and companies know that if they use it, it won’t fail,” says Tim Shaw, CEO of Shaw Almex.

Although their work is international, the company is proudly Canadian. “MSTA CANADA is one of the best organizations we belong to,” says Tim.

In 2016, the company began providing global services and has acquired a reputation for working in the most challenging locations on earth. In 2018, they completed the splicing and installation of a Sempertrans conveyor belt for Lafarge Surma that runs from India to Bangladesh. At 34 km, it’s the longest single flight conveyor belt in the world — so large it can be seen from the International Space Station.

“That project was our Mount Everest: if you can climb that, you can climb anything,” says Tim.

In 2021, the company is introducing their newest product, Almex Intelligence (Ai), a hands-free Android™ wearable computer for industrial workers that facilitates remote assistance from experts. The rugged device is ideal for the tough conditions found in mines. The hands-free, voice-controlled software can be used for document navigation, guided workflow or video calls with an off-site expert. The technology improves safety and helps reduce downtime by up to 75% and is particularly helpful when remote collaboration and intervention are preferable to long-distance travel.

Shaw Almex also provides certification training and is working on expanding its training program to help industry workers such as coal miners transition into new fields.

“We’re a global integrated supplier, but our products and services are all built around our core expertise: bulk material handling,” says Tim.

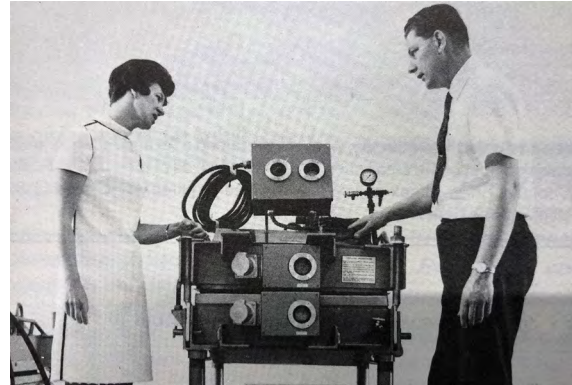

Learn more on **page 26**



STAFF

MSTA CANADA is Canada's #1 mining service and supply association, and membership ensures you gain access to world class market intelligence, industry news, business development opportunities, to opportunities from a robust ecosystem, representation for strategic government policies and initiatives that support our sector.

MSTA CANADA's mandate is to connect members to opportunities to grow their businesses and promote themselves within a vibrant and globally competitive mining supply chain. MSTA CANADA members are highly engaged solutions-focused leaders who are recognized as thought leaders and partners in helping to support the mining industry around the world.

Join MSTA CANADA and engage in the Canadian mining community, including some of our members featured here. MSTA CANADA membership provide all individuals within your organization access to the full suite of member benefits.



Ryan McEachern
Managing Director



Dolores Wharton
Director -
Global Events



Stephanie Alvarez
Manager -
Business Development



Linda Collins
Office Manager

BOARD OF DIRECTORS

PRESIDENT
Ben Sharpe

1st VICE PRESIDENT
Christine Parkes

2nd VICE PRESIDENT
Marc Maurice

TREASURER
Stuart Lister

MANAGING DIRECTOR
Ryan McEachern

SECRETARY
Ryan McEachern

DIRECTORS

Ben Sharpe
Rockwell Automation

Karly Winfield
PROVIX

Rami Faour
Progesys

Stuart Lister
MacLean Engineering

Marc Maurice
Eco-Technologies

Farivar Raffiei
Motion Metrics International

Catharine Shaw
Shaw Consulting

Christine Parkes
Mine Cable Services

Nancy Liu
ThreeDify Inc.

Tara Gilfillan
Optimize Group



Below is a list of MSTA CANADA members with profiles in this year’s Compendium. Members not appearing in this issue may still be viewed on their respective member pages on the MSTA CANADA website at www.mstacanada.ca

A

| | |
|-----------------------------------|----|
| Accutron Instruments Inc..... | 69 |
| Adria Power Systems..... | 33 |
| Almex Group..... | 26 |
| American Biltrite Ltd..... | 46 |
| Aspen Custom Trailers..... | 38 |
| Attwell Plastics Corporation..... | 25 |

B

| | |
|---------------------------------|--------|
| Boundary Equipment Co. Ltd..... | 47, 61 |
| BPT Components & Parts Inc..... | 65 |

C

| | |
|---------------------------------|----|
| Canadian Wear Technologies..... | 48 |
| Coding Metrology Inc..... | 53 |
| Cole International Inc..... | 63 |
| Corem..... | 54 |

E

| | |
|--------------------------------------|----|
| ECO Technologies..... | 35 |
| Element International Trade Inc..... | 57 |
| Eutectic Canada Inc..... | 39 |

G

| | |
|--|----|
| G+ Industrial Plastics..... | 70 |
| GEM Systems Inc..... | 41 |
| Global Physical Asset Management, Inc..... | 18 |
| Greater Sudbury Economic Development..... | 20 |
| Green Canpump Inc..... | 51 |

H

| | |
|----------------------------------|--------|
| Heath & Sherwood..... | 49 |
| Hepburn Engineering Inc..... | 24, 45 |
| Horne Conveyance Safety Ltd..... | 43 |
| HydroTech Mining Inc..... | 52 |

I

| | |
|--------------------|----|
| Intelline Inc..... | 31 |
|--------------------|----|

L

| | |
|---------------------------|----|
| Laval Lab Inc..... | 17 |
| L&M Powertrain Parts..... | 66 |

M

| | |
|--------------------------------------|----|
| MacLean..... | 66 |
| McCloskey International..... | 50 |
| McCue Engineering Contractors..... | 72 |
| Mine Cable Services Corporation..... | 34 |
| Motion Metrics..... | 28 |

P

| | |
|--|----|
| Prospectors & Developers Association of Canada (PDAC)..... | 22 |
| PROVIX Inc..... | 29 |

R

| | |
|---|----|
| Rail-Veyor Technologies Global Inc..... | 27 |
| RWDI..... | 30 |

S

| | |
|---------------------|----|
| SightPower Inc..... | 55 |
|---------------------|----|

T

| | |
|--------------------------------------|----|
| Terraplus..... | 42 |
| ThreeDify Inc..... | 59 |
| Titan Environmental Containment..... | 37 |
| Topax Protektive Packaging..... | 58 |
| TopVu Ltd..... | 44 |
| Trojan Tire Inc..... | 67 |

V

| | |
|----------------------------|--------|
| Valley Blades Limited..... | 40, 62 |
|----------------------------|--------|





**JOIN NOW OR CONTACT
US TODAY AND TAKE
YOUR NETWORKING AND
MARKETING ACTIVITIES
TO THE NEXT LEVEL!**

Mining Suppliers Trade Association Canada

MSTA CANADA

Suite 130, 7111 Syntex Drive
Mississauga, Ontario L5N 8C3
Canada

Phone: 1-647-929-MSTA (6782)

Email: minesupply@mstacanada.ca

www.mstacanada.ca



MSTACANADA™
MINING SUPPLIERS TRADE ASSOCIATION