

FOREMOST APEX-65

Versatile, powerful, and safe drilling rig for RC mineral exploration applications.

The Apex 65 features a proprietary feed system that reduces maintenance costs, increases safety, and improves performance. With 65,000 lbs of pullback and the ability to be configured on tracks or chassis, the Apex 65 can satisfy a wide range of exploration requirements.



DESIGN. BUILD. PERFORM.
Engineered solutions for the resource industry.

FOREMOST

FOREMOST APEX 65

TOP DRIVE

Stroke	25 ft (7.6 m)
Hoist Capacity	Pullback: 65,000 lbs (29,484kg) Pulldown: 22,000 lbs (9,979 kg)
Hoist Speed	150 ft/min (46 m/min)
Torque (stall)	22,000 ft-lbs (29828 Nm)
Rotation Speed	Low Speed: 12,000 ft-lbs (16,270 N-m) @ 110 RPM High Speed: 8,200 ft-lbs (11,118 N-m) @ 165 RPM
Spindle Thru Hole	4-1/2" (114 mm)
Tilting Capacity	1,500 lbs (680 kg) @ 70 degrees

COMPRESSOR

Air Flow	1250 cfm
Pressure	350 psi
Plumbing	1,000 psi rated
Engine Power	675 HP (tier 3 or tier 4)

TABLE

Opening	14" (356 mm)
Hands Free Breakout	4" - 8-5/8" (102 mm - 219 mm) OD Pipe

SERVICE WINCH

Wire Rope Length	140 ft (42.7 m)
Wire Rope Diameter	1/2" (13 mm)
Line Pull on Bare Drum	6,000 lbs (2,722 kg)
Line Speed on Full Drum	100 ft/min (30 m/min)

WATER AND FOAM INJECTION

Capacity	24 gpm
Pressure	700 psi

DIMENSIONS

Length	Tracked: 40' 1" (12.2 m) Chassis: 41' 1" (12.5 m)
Height	Tracked: 13' 4" (4.1 m) Chassis: 13' 5" (4.1 m)
Width	Tracked: 10' 5" (3.2 m) Chassis: 8' 6" (2.6 m)
Weight	Tracked: 72,600 lbs (32,930 kg) Chassis: 70,610 lbs (32,020 kg)

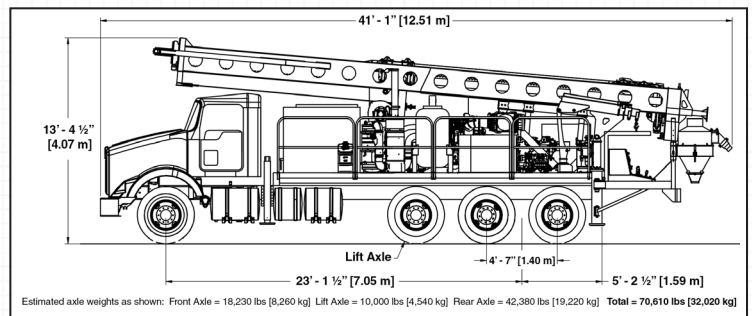
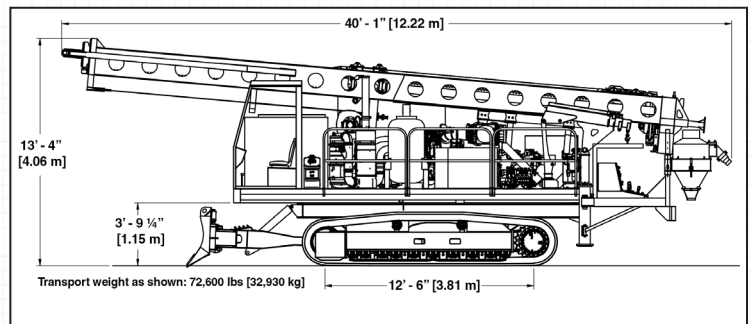

OPTIONS

Carrier	Tracks, chassis, or deck kit
Engine	Power: 675 HP Emissions: Tier 3 (Stage IIIa) or Tier 4 (Stage IV)
Compressor	1000/500
Pipehandling	Foremost hands free pipehandling system
Misc. Options	Sampling cyclone, sandline winch, hose minder winch, special request water pump, side mounted breakout for casing/hammers/bits, data acquisition, cold weather package, fire suppression system.

FEATURES

- Vertical to 45 degrees angle drilling
- Cylinder driven gear feed system
- Hydraulically operated split table
- Remote driller's console
- Hydraulic split deck (tracked configuration) 0-25 degrees
- Mast base rotation barrier
- Blowdown valve
- Electric over hydraulic controls
- Bellybox controls for set up and pipehandling